



# c-pro 3

## PROGRAMMABLE CONTROLLERS



ENGLISH

### HARDWARE MANUAL ver. 3.2

CODE 114CP3E324

## Important

### Important

Read this document carefully before the installation and before the use and follow all the additional information for the installation and for the electrical connection; keep this document close to the devices for future consultations.

The following symbols support the reading of the document:



it indicates a suggestion



it indicates an additional information to be followed.

The devices must be disposed according to the local legislation about the collection for electrical and electronic equipment.



## Index

1.	INTRODUCTION.....	5
1.1.	Introduction.....	5
2.	DESCRIPTION.....	8
2.1.	Description <i>c-pro 3 hecto</i> and <i>c-pro 3 hecto+</i> .....	8
2.2.	Description <i>c-pro 3 mega</i> .....	9
2.3.	Description <i>c-pro 3 mega+</i> .....	10
2.4.	Description <i>c-pro 3 NODE mega</i> .....	12
2.5.	Description <i>c-pro 3 EXP hecto</i> and <i>c-pro 3 EXP hecto+</i> .....	13
3.	SIZE AND INSTALLATION.....	14
3.1.	Size <i>c-pro 3 hecto</i> , <i>c-pro 3 hecto+</i> , <i>c-pro 3 EXP hecto</i> and <i>c-pro 3 EXP hecto+</i> .....	14
3.2.	Size <i>c-pro 3 mega</i> and <i>c-pro 3 mega+</i> .....	14
3.3.	Size <i>c-pro 3 NODE mega</i> .....	15
3.4.	Installation.....	16
3.5.	Additional information for installation.....	16
4.	ELECTRICAL CONNECTION.....	17
4.1.	Electrical connection <i>c-pro 3 hecto</i> and <i>c-pro 3 hecto+</i> .....	17
4.1.1.	Meaning of the connectors of <i>c-pro 3 hecto</i> and of <i>c-pro 3 hecto+</i> .....	17
4.1.2.	Example of electrical connection of <i>c-pro 3 hecto</i> .....	24
4.2.	Electrical connection <i>c-pro 3 mega</i> and <i>c-pro 3 NODE mega</i> .....	25
4.2.1.	Meaning of the connectors of <i>c-pro 3 mega</i> and of <i>c-pro 3 NODE mega</i> .....	25
4.2.2.	Example of electrical connection of <i>c-pro 3 mega</i> .....	33
4.3.	Electrical connection <i>c-pro 3 mega+</i> .....	34
4.3.1.	Meaning of the connectors of <i>c-pro 3 mega+</i> .....	34
4.3.2.	Example of electrical connection of <i>c-pro 3 mega+</i> .....	44
4.4.	Electrical connection <i>c-pro 3 EXP hecto</i> and <i>c-pro 3 EXP hecto+</i> .....	46
4.4.1.	Meaning of the connectors of <i>c-pro 3 EXP hecto</i> and of <i>c-pro 3 EXP hecto+</i> .....	46
4.4.2.	Example of electrical connection of <i>c-pro 3 EXP hecto</i> .....	51
4.5.	Additional information for electrical connection.....	52
5.	USER INTERFACE.....	53
5.1.	Keyboard.....	53
5.2.	Signalling LEDs.....	53
5.2.1.	LEDs at the front of the device.....	53
5.2.2.	LEDs on the RS-485 ports.....	54
6.	CONFIGURATION.....	55
6.1.	Configuring a programmable controller.....	55
6.1.1.	Configuring a built-in programmable controller.....	55
6.1.2.	Configuring a blind programmable controller.....	57
6.2.	Configuring an I / O expansion.....	58
6.3.	Configuring a device through an user interface ( <i>Vgraph</i> , <i>Vtouch</i> or <i>Vroom</i> ).....	59
6.4.	List of configuration parameters.....	60
6.4.1.	List of configuration parameters of <i>c-pro 3 hecto</i> and of <i>c-pro 3 hecto+</i> .....	60
6.4.2.	List of configuration parameters of <i>c-pro 3 mega</i> and of <i>c-pro 3 NODE mega</i> .....	67
6.4.3.	List of configuration parameters of <i>c-pro 3 mega+</i> .....	77
6.4.4.	List of configuration parameters of <i>c-pro 3 EXP hecto</i> and of <i>c-pro 3 EXP hecto+</i> .....	92
7.	USER INTERFACES.....	96
7.1.	Preliminary information.....	96
7.2.	<i>Vgraph</i> .....	96
7.2.1.	Introduction.....	96
7.2.2.	Summarizing table of the main features and available models.....	96
7.2.3.	Size.....	97

- 7.3. *Vtouch*.....98
  - 7.3.1. Introduction .....98
  - 7.3.2. Summarizing table of the main features and available models .....98
  - 7.3.3. Size.....99
- 7.4. *Vroom*.....100
  - 7.4.1. Introduction .....100
  - 7.4.2. Summarizing table of the main features and available models .....100
  - 7.4.3. Size.....101
- 8. ACCESSORIES.....102
  - 8.1. Programming kit EVIF20TUXI.....102
    - 8.1.1. Introduction .....102
    - 8.1.2. Description .....102
    - 8.1.3. Size.....103
    - 8.1.4. Connection to the Personal Computer.....103
  - 8.2. Programming key EVKEY10.....103
    - 8.2.1. Introduction .....103
    - 8.2.2. Description .....103
    - 8.2.3. Size.....104
    - 8.2.4. Connection to the controller .....104
- 9. TECHNICAL DATA.....105
  - 9.1. Technical data .....105

# 1. INTRODUCTION

## 1.1. Introduction

**c-pro 3** is a family of programmable controllers.

The family consists of:

- programmable controllers (**c-pro 3 hecto**, **c-pro 3 hecto+**, **c-pro 3 mega**, **c-pro 3 mega+** and **c-pro 3 NODE mega**)
- I / O expansions (**c-pro 3 EXP hecto** and **c-pro 3 EXP hecto+**).

**c-pro 3 hecto** is available in blind version and can be used for example with an user interface such as **Vgraph**, **Vtouch** or **Vroom**.

The controllers have got:

- real time clock
- 3 analog inputs configurable via configuration parameter for PTC / NTC / Pt 1000 probes / 0-20 mA / 4-20 mA / 0-5 V ratiometric / 0-10 V transducers
- 5 non optoisolated free of voltage digital inputs
- 3 analog outputs of which 1 non optoisolated PWM output and 2 non optoisolated outputs configurable via configuration parameter for 0-20 mA / 4-20 mA / 0-10 V signal
- 6 digital outputs (electromechanical relays) of which five 5 res. A @ 250 VAC SPST outputs and one 8 res. A @ 250 VAC SPDT output
- 3 non optoisolated communication ports of which 1 CAN port with CANbus communication protocol, 1 RS-485 port with Modbus master / slave communication protocol (configurable via application software) and 1 programming and debugging port.

Through the I / O expansion **c-pro 3 EXP hecto** or **c-pro 3 EXP hecto+** it is possible to increase the number of inputs and outputs.

**c-pro 3 hecto+** is available in the following versions:

- with 128 x 64 pixel single colour LCD graphic display (black with rearlighting through white LEDs) and with a 6 buttons (with preset functions) keyboard made of silicone rubber integrated in the controller, hereinafter also called "built-in versions"
- blind (can be used for example with an user interface such as **Vgraph**, **Vtouch** or **Vroom**), hereinafter also called "blind versions".

The controllers have got:

- real time clock
- alarm buzzer (not available in the blind versions)
- 4 analog inputs of which 3 configurable via configuration parameter for PTC / NTC / Pt 1000 probes / 0-20 mA / 4-20 mA / 0-5 V ratiometric / 0-10 V transducers and 1 for NTC probes
- 5 optoisolated digital inputs at 24 VAC / DC
- 3 analog outputs of which 1 non optoisolated PWM output and 2 non optoisolated outputs configurable via configuration parameter for 0-20 mA / 4-20 mA / 0-10 V signal
- 6 digital outputs (electromechanical relays) of which five 3 res. A @ 250 VAC SPST outputs and one 5 res. A @ 250 VAC SPDT output
- 3 non optoisolated communication ports of which 1 CAN port with CANbus communication protocol, 1 RS-485 port with Modbus master / slave communication protocol (configurable via application software) and 1 programming and debugging port.

Through the I / O expansion **c-pro 3 EXP hecto** or **c-pro 3 EXP hecto+** it is possible to increase the number of inputs and outputs.

**c-pro 3 mega** and **c-pro 3 NODE mega** are available in the following versions:

- with 122 x 32 pixel single colour LCD graphic display (black with rearlighting through white LEDs) and with a 6 buttons (with preset functions) keyboard made of silicone rubber integrated in the controller, hereinafter also called "built-in versions"
- blind (can be used for example with an user interface such as **Vgraph**, **Vtouch** or **Vroom**), hereinafter also called "blind versions".

The controllers have got:

- real time clock
- alarm buzzer (not available in the blind versions)

- 5 analog inputs configurable via configuration parameter for PTC / NTC / Pt 1000 probes / 0-20 mA / 4-20 mA / 0-5 V ratiometric / 0-10 V transducers
- 7 optoisolated digital inputs at 24 VAC / DC
- 3 analog outputs of which 1 non optoisolated PWM output and 2 non optoisolated outputs configurable via configuration parameter for 0-20 mA / 4-20 mA / 0-10 V signal
- 8 digital outputs (electromechanical relays) of which three 5 res. A @ 250 VAC SPST outputs, four 8 res. A @ 250 VAC SPST outputs and one 8 res. A @ 250 VAC SPDT output
- 4 non optoisolated communication ports of which 1 CAN port with CANbus communication protocol, 1 RS-485 port with Modbus slave communication protocol, 1 RS-485 port with Modbus master / slave communication protocol (configurable via application software) and 1 programming and debugging port
- 1 non optoisolated communication port for gateway **c-pro 3 plug-in** (available in **c-pro 3 NODE mega** only).

Through the I / O expansion **c-pro 3 EXP hecto** or **c-pro 3 EXP hecto+** it is possible to increase the number of inputs and outputs.

**c-pro 3 mega+** is available in the following versions:

- with 122 x 32 pixel single colour LCD graphic display (black with rearlighting through white LEDs) and with a 6 buttons (with preset functions) keyboard made of silicone rubber integrated in the controller, hereinafter also called "built-in versions"
- blind (can be used for example with an user interface such as **Vgraph**, **Vtouch** or **Vroom**), hereinafter also called "blind versions".

The controllers have got:

- real time clock
- alarm buzzer (not available in the blind versions)
- 8 analog inputs of which 3 configurable via configuration parameter for NTC / 0-20 mA / 4-20 mA transducers and 5 configurable via configuration parameter for PTC / NTC / Pt 1000 probes / 0-20 mA / 4-20 mA / 0-5 V ratiometric / 0-10 V transducers
- 12 optoisolated digital inputs at 24 VAC / DC
- 5 analog outputs of which 1 non optoisolated PWM output, 2 non optoisolated outputs configurable via configuration parameter for PWM / 0-10 V signal and 2 non optoisolated outputs configurable via configuration parameter for 0-20 mA / 4-20 mA / 0-10 V signal
- 10 digital outputs (electromechanical relays) of which five 5 res. A @ 250 VAC SPST outputs, four 8 res. A @ 250 VAC SPST outputs and one 8 res. A @ 250 VAC SPDT output
- 5 non optoisolated communication ports of which 1 CAN port with CANbus communication protocol, 1 CAN port or MP-Bus port (according to the model), 1 RS-485 port with Modbus slave communication protocol, 1 RS-485 port with Modbus master / slave communication protocol (configurable via application software) and 1 programming and debugging port.

Through the I / O expansion **c-pro 3 EXP hecto** or **c-pro 3 EXP hecto+** it is possible to increase the number of inputs and outputs.

**c-pro 3 EXP hecto** is available in blind version and can be used for example with a programmable controller such as **c-pro 3 hecto**, **c-pro 3 hecto+**, **c-pro 3 mega** or **c-pro 3 NODE mega**.

The expansion has got:

- 3 analog inputs configurable via configuration parameter for PTC / NTC / Pt 1000 probes / 0-20 mA / 4-20 mA / 0-5 V ratiometric / 0-10 V transducers
- 5 non optoisolated free of voltage digital inputs
- 3 analog outputs of which 1 non optoisolated PWM output and 2 non optoisolated outputs configurable via configuration parameter for 0-20 mA / 4-20 mA / 0-10 V signal
- 6 digital outputs (electromechanical relays) of which five 5 res. A @ 250 VAC SPST outputs and one 8 res. A @ 250 VAC SPDT output
- 2 non optoisolated communication ports of which 1 CAN port with CANbus communication protocol and 1 port to update the firmware of the instrument.

**c-pro 3 EXP hecto+** is available in blind version and can be used for example with a programmable controller such as **c-pro 3 hecto**, **c-pro 3 hecto+**, **c-pro 3 mega** or **c-pro 3 NODE mega**.

The expansion has got:

- 4 analog inputs of which 3 configurable via configuration parameter for PTC / NTC / Pt 1000 probes / 0-20 mA / 4-20 mA / 0-5 V ratiometric / 0-10 V transducers and 1 for NTC probes
- 5 optoisolated digital inputs at 24 VAC / DC
- 3 analog outputs of which 1 non optoisolated PWM output and 2 non optoisolated outputs configurable via configuration parameter for 0-20 mA / 4-20 mA / 0-10 V signal
- 6 digital outputs (electromechanical relays) of which five 3 res. A @ 250 VAC SPST outputs and one 5 res. A @ 250 VAC SPDT output
- 2 non optoisolated communication ports of which 1 CAN port with CANbus communication protocol and 1 port to update the firmware of the instrument.

Through the development environment UNI-PRO 3 (to order separately) it is possible to realize the application software and through the programming kit EVIF20TUXI (to order separately) it is possible to program the controllers.

The devices look in case 4 DIN modules (**c-pro 3 hecto**, **c-pro 3 hecto+**, **c-pro 3 EXP hecto** and **c-pro 3 EXP hecto+**), 10 DIN modules (**c-pro 3 mega** and **c-pro 3 mega+**) or 14 DIN modules (**c-pro 3 NODE mega**).

Installation is in electrical panel, on DIN rail.

Through the programming key EVKEY 10 (to order separately) it is also possible to make the upload and the download of the configuration parameters.

## 2. DESCRIPTION

### 2.1. Description c-pro 3 hecto and c-pro 3 hecto+

The following drawing shows the aspect of *c-pro 3 hecto* and of *c-pro 3 hecto+*.

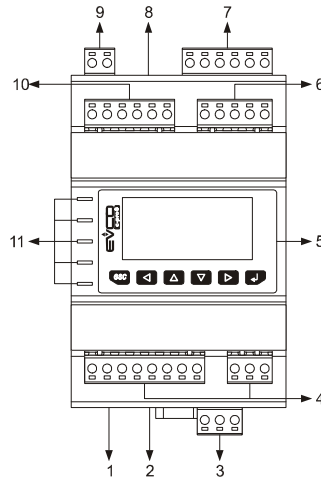

The following table shows the meaning of the parts of the controller.

Part	Meaning
1	RS-485 port with Modbus master / slave communication protocol
2	micro-switch to: <ul style="list-style-type: none"> <li>- plug in the termination of the RS-485 port</li> <li>- polarize the network of the RS-485 port</li> <li>- plug in the termination of the CAN port</li> </ul>
3	CAN port
4	digital outputs
5	display and keyboard (available in <i>c-pro 3 hecto+</i> only, not available in the blind versions)
6	analog outputs in <i>c-pro 3 hecto</i> , analog inputs and analog outputs in <i>c-pro 3 hecto+</i>
7	analog inputs
8	programming and debugging port
9	power supply
10	digital inputs
11	signalling LEDs



## 2.2. Description *c-pro 3 mega*

The following drawing shows the aspect of *c-pro 3 mega*.

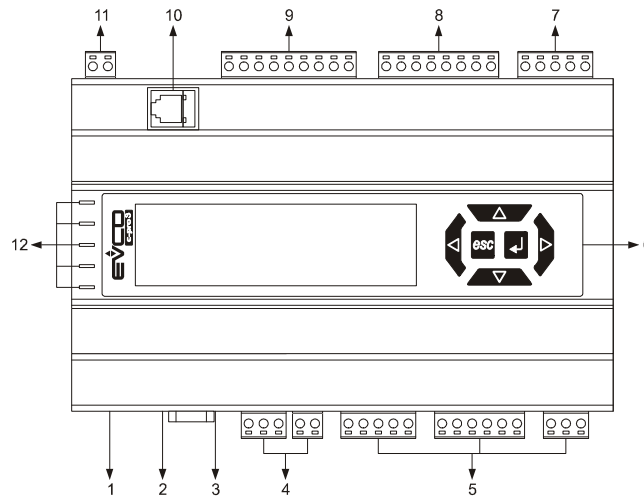

The following table shows the meaning of the parts of the controller.

Part	Meaning
1	RS-485 port with Modbus slave communication protocol (hereinafter also called first RS-485 port)
2	RS-485 port with Modbus master / slave communication protocol (hereinafter also called second RS-485 port)
3	micro-switch to: <ul style="list-style-type: none"> <li>- plug in the terminations of the RS-485 ports</li> <li>- polarize the network of the second RS-485 port</li> <li>- plug in the termination of the CAN port</li> </ul>
4	CAN port
5	digital outputs
6	display and keyboard (not available in the blind versions)
7	analog outputs
8	digital inputs
9	analog inputs
10	programming and debugging port
11	power supply
12	signalling LEDs

## 2.3. Description c-pro 3 mega+

The following drawing shows the aspect of **c-pro 3 mega+**.

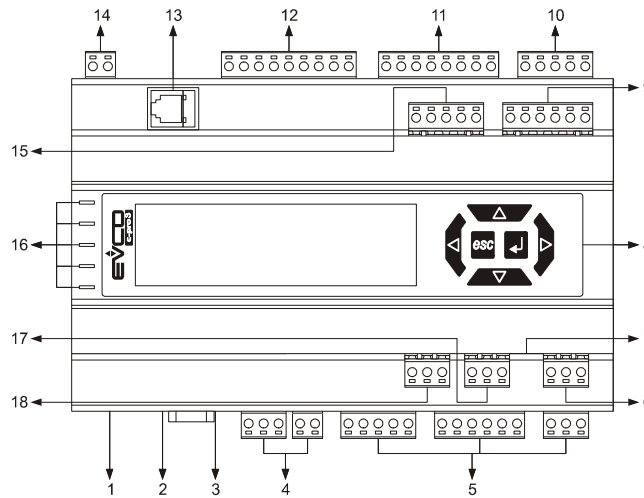

The following table shows the meaning of the parts of the controller.

Part	Meaning
1	RS-485 port with Modbus slave communication protocol (hereinafter also called first RS-485 port)
2	RS-485 port with Modbus master / slave communication protocol (hereinafter also called second RS-485 port)
3	micro-switch to: <ul style="list-style-type: none"> <li>- plug in the terminations of the RS-485 ports</li> <li>- polarize the network of the second RS-485 port</li> <li>- plug in the termination of the first CAN port</li> </ul>
4	first CAN port
5	digital outputs 1... 8
6	second CAN port or MP-Bus port (according to the model)
7	micro-switch to plug in the termination of the second CAN port
8	display and keyboard (not available in the blind versions)
9	digital inputs 8... 12
10	analog outputs 1... 3
11	digital inputs 1... 7
12	analog inputs 1... 5

13	programming and debugging port
14	power supply
15	analog inputs 6... 8
16	signalling LEDs
17	analog outputs 4 and 5
18	digital outputs 9 and 10

## 2.4. Description c-pro 3 NODE mega

The following drawing shows the aspect of **c-pro 3 NODE mega**.

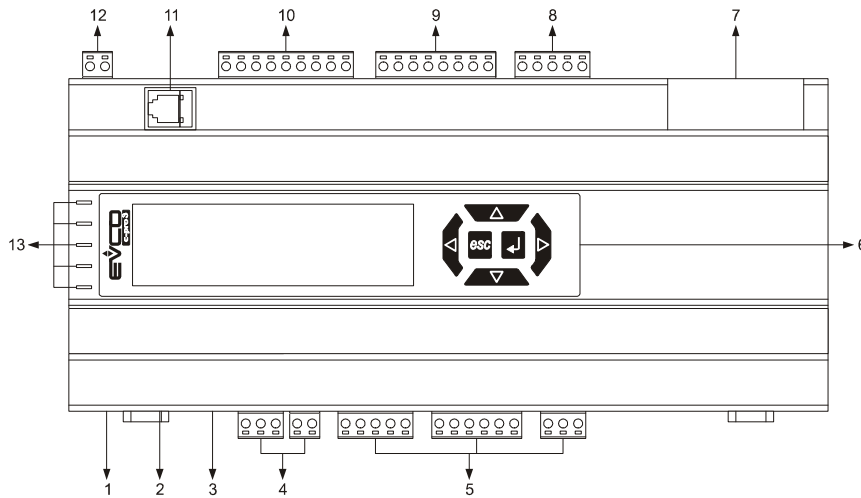

The following table shows the meaning of the parts of the controller.

Part	Meaning
1	RS-485 port with Modbus slave communication protocol (hereinafter also called first RS-485 port)
2	RS-485 port with Modbus master / slave communication protocol (hereinafter also called second RS-485 port)
3	micro-switch to: <ul style="list-style-type: none"> <li>- plug in the terminations of the RS-485 ports</li> <li>- polarize the network of the second RS-485 port</li> <li>- plug in the termination of the CAN port</li> </ul>
4	CAN port
5	digital outputs
6	display and keyboard (not available in the blind versions)
7	slot for gateway <b>c-pro 3 plug-in</b>
8	analog outputs
9	digital inputs
10	analog inputs
11	programming and debugging port
12	power supply
13	signalling LEDs

## 2.5. Description *c-pro 3 EXP hecto* and *c-pro 3 EXP hecto+*

The following drawing shows the aspect of *c-pro 3 EXP hecto* and of *c-pro 3 EXP hecto+*.

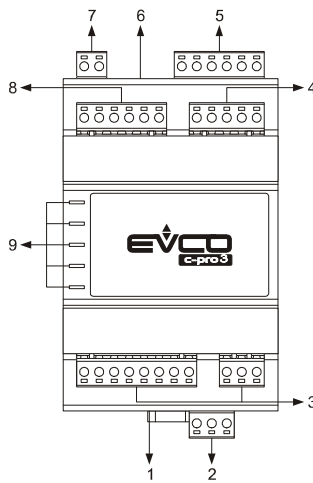

The following table shows the meaning of the parts of the expansion.

Part	Meaning
1	micro-switch to plug in the termination of the CAN port
2	CAN port
3	digital outputs
4	analog outputs in <i>c-pro 3 EXP hecto</i> , analog inputs and analog outputs in <i>c-pro 3 EXP hecto+</i>
5	analog inputs
6	port to update the firmware of the expansion
7	power supply
8	digital inputs
9	signalling LEDs

### 3. SIZE AND INSTALLATION

#### 3.1. Size *c-pro 3 hecto*, *c-pro 3 hecto+*, *c-pro 3 EXP hecto* and *c-pro 3 EXP hecto+*

4 DIN modules; size in mm (in).

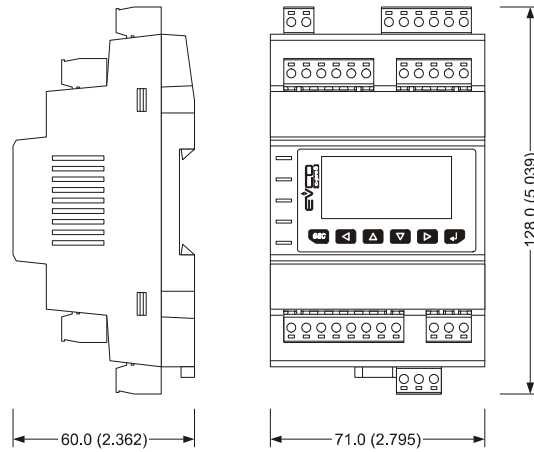

#### 3.2. Size *c-pro 3 mega* and *c-pro 3 mega+*

10 DIN modules; size in mm (in).

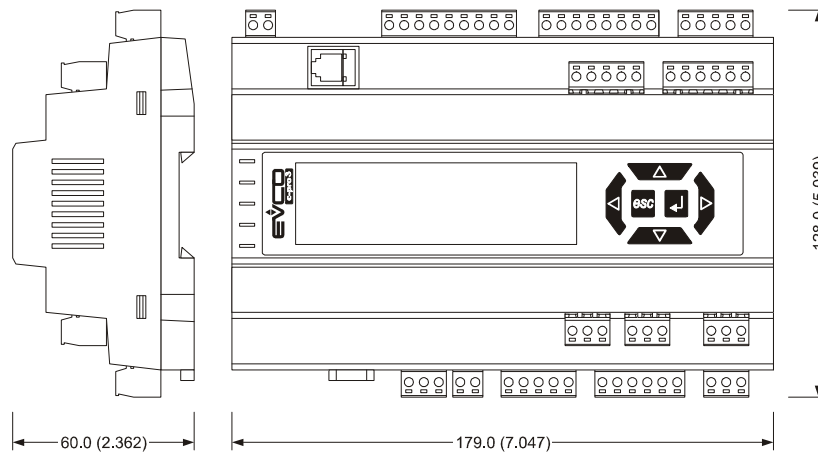

### 3.3. Size c-pro 3 NODE mega

14 DIN modules; size in mm (in).

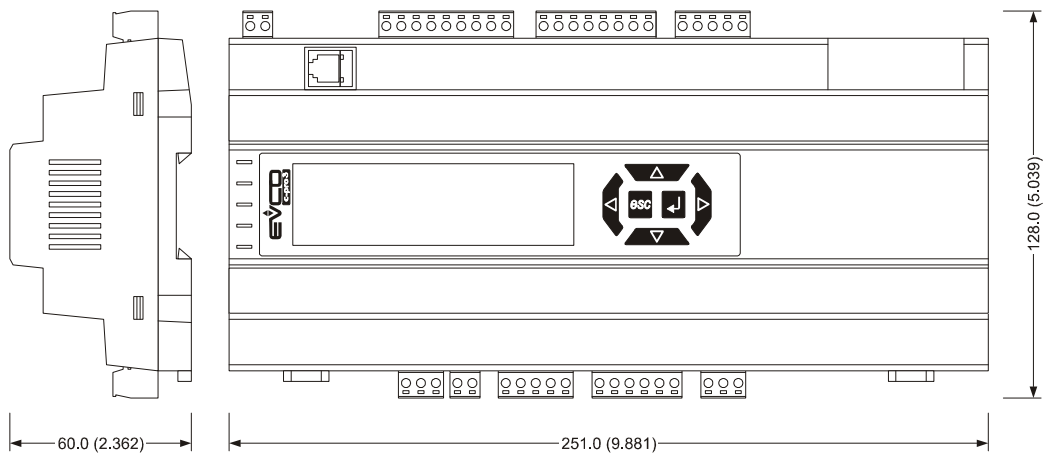

### 3.4. Installation

On DIN rail 35.0 x 7.5 mm (1.377 x 0.295 in) or 35.0 x 15.0 mm (1.377 x 0.590 in).

To install the devices operate as shown in the following drawing.

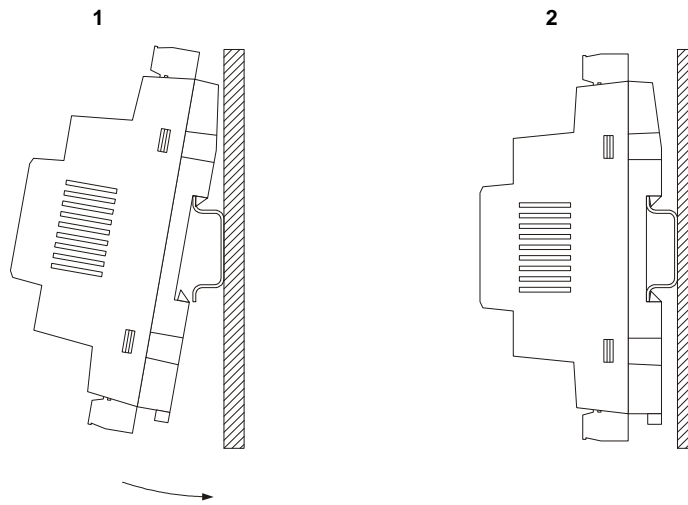

To remove the devices remove possible extractable screw terminal blocks plugged at the bottom first, then operate on the DIN rail clips with a screwdriver as shown in the following drawing.

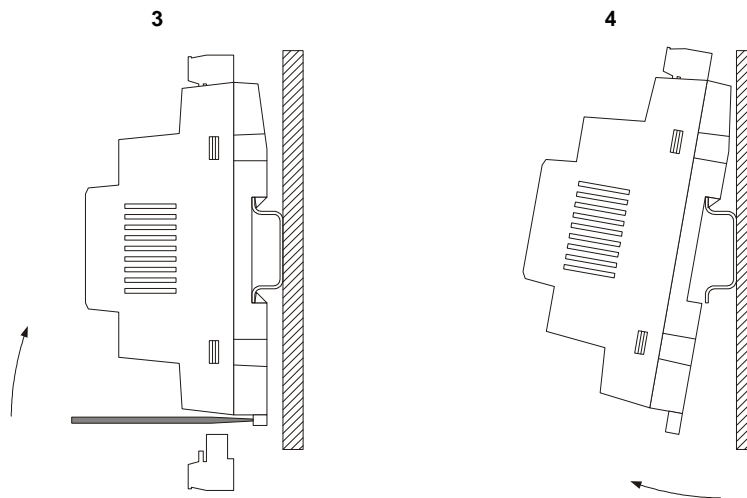

To install the devices again press the DIN rail clips to the end first.

### 3.5. Additional information for installation

- working conditions (working temperature, humidity, etc.) must be between the limits indicated in the technical data
- do not install the devices close to heating sources (heaters, hot air ducts, etc.), equipments provided with big magnetos (big speakers, etc.), locations subject to direct sunlight, rain, humidity, dust, mechanical vibrations or bumps
- according to the safety legislation, the protection against electrical parts must be ensured by a correct installation of the devices; the parts that ensure the protection must be installed so that you can not remove them if not by using a tool.



## 4. ELECTRICAL CONNECTION

### 4.1. Electrical connection c-pro 3 hecto and c-pro 3 hecto+

#### 4.1.1. Meaning of the connectors of c-pro 3 hecto and of c-pro 3 hecto+

The following drawing shows the connectors of c-pro 3 hecto and of c-pro 3 hecto.

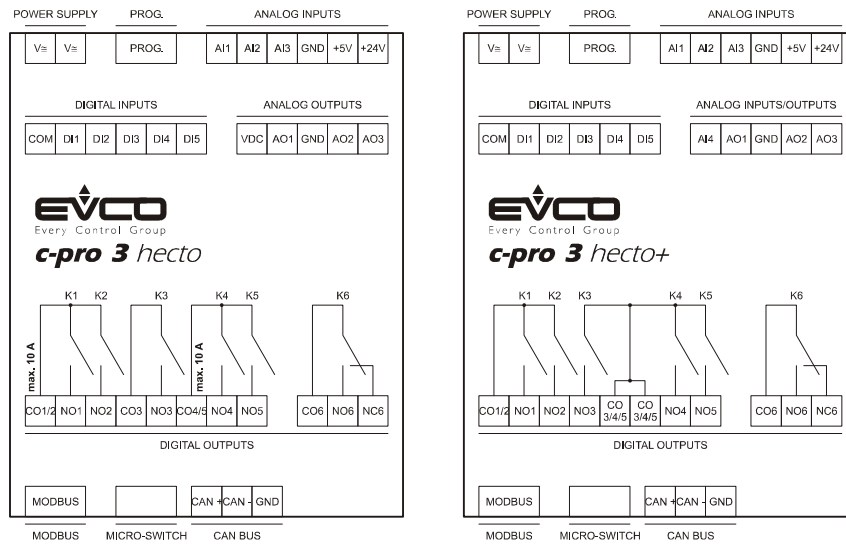

The following tables show the meaning of the connectors.

#### MODBUS

RS-485 port with Modbus master / slave communication protocol (configurable via application software).

The following drawing shows the aspect of the RS-485 port.

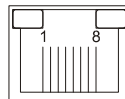

The following table shows the meaning of the pins of the RS-485 port.

Pin	Meaning
1	common
2	not connected
3	not connected
4	D0 = B = - (terminal 0 of the transceiver)
5	D1 = A = + (terminal 1 of the transceiver)
6	not connected
7	not connected

8 | not connected



The maximum length of the connecting cables of the RS-485 port is 1,000 m (3,280 ft); also look at the *Modbus specifications and implementation guides manual* (the document is available on the internet site [www.modbus.org](http://www.modbus.org)).

Connect the RS-485 port using a twisted pair.

The following table shows the *function codes* supported by the controller.

Function code	Meaning
FC 01	read coils
FC 02	read discrete inputs
FC 03	read multiple registers
FC 04	read input registers
FC 05	write single coil
FC 06	write single register
FC 08	diagnostic
FC 15	write multiple coils
FC 16	write multiple registers
FC 23	read write multiple registers

For the settings about the RS-485 port look at chapter 6 “CONFIGURATION”.

**MICRO-SWITCH**

Micro-switch to:

- plug in the termination of the RS-485 port (120 Ω, 0.25 W); position micro-switch 1 on position ON to plug in the termination of the RS-485 port (plug in the termination of the first and of the last element of the network)



- polarize the network of the RS-485 port (560 Ω, 0.25 W); position micro-switches 2 and 3 on position ON to polarize the network of the RS-485 port (the network must be polarized by an element of the network same).



- plug in the termination of the CAN port (120 Ω, 0.5 W); position micro-switch 4 on position ON to plug in the termination of the CAN port (plug in the termination of the first and of the last element of the network).



**CAN BUS**

CAN port.

Terminal	Meaning
CAN +	signal +
CAN -	signal -
GND	ground

The maximum number of devices that can make a CAN network (32) depends on the bus load; the bus load depends on the baud rate of the CANbus communication and on the kind of device in the network.



For example: a CAN network can be made of a programmable controller, of four I / O expansions and of four user interfaces with baud rate 500,000 baud.



The maximum length of the connecting cables of the CAN port depends on the baud rate of the CANbus communication, as follows:

- 1,000 m (3,280 ft) with baud rate 20,000 baud
- 500 m (1,640 ft) with baud rate 50,000 baud
- 250 m (820 ft) with baud rate 125,000 baud
- 50 m (164 ft) with baud rate 500,000 baud.

Connect the CAN port using a twisted pair.

For the settings about the CAN port look at chapter 6 “CONFIGURATION”.

**DIGITAL OUTPUTS**

In c-pro 3 hecto.

Digital outputs 1, 2, 3, 4 and 5 (electromechanical relays).

Terminal	Meaning
CO1/2	common digital outputs 1 and 2
NO1	normally open contact digital output 1

NO2	normally open contact digital output 2
CO3	common digital output 3
NO3	normally open contact digital output 3
CO4/5	common digital outputs 4 and 5
NO4	normally open contact digital output 4
NO5	normally open contact digital output 5

Digital output 6 (electromechanical relay).

Terminal	Meaning
CO6	common digital output 6
NO6	normally open contact digital output 6
NC6	normally closed contact digital output 6



The maximum length of the connecting cables of the digital *hecto* cuts is 100 m (328 ft).

The maximum current allowed on the loads is 10 A.

## DIGITAL OUTPUTS

In *c-pro 3 hecto+*.

Digital outputs 1, 2, 3, 4 and 5 (electromechanical relays).

Terminal	Meaning
CO1/2	common digital outputs 1 and 2
NO1	normally open contact digital output 1
NO2	normally open contact digital output 2
NO3	normally open contact digital output 3
CO3/4/5	common digital outputs 3, 4 and 5
CO3/4/5	common digital outputs 3, 4 and 5
NO4	normally open contact digital output 4
NO5	normally open contact digital output 5

Digital output 6 (electromechanical relay).

Terminal	Meaning
CO6	common digital output 6
NO6	normally open contact digital output 6
NC6	normally closed contact digital output 6



The maximum length of the connecting cables of the digital(6) non

**hecto only)**

Analog outputs.

Terminal	Meaning
VDC	power supply driving analog output 1 (24 VDC, 50 mA max.)
AO1	analog output 1 (PWM signal)
GND	ground
AO2	analog output 2 (configurable via configuration parameter for 0-20 mA / 4-20 mA / 0-10 V signal)
AO3	analog output 3 (configurable via configuration parameter for 0-20 mA / 4-20 mA / 0-10 V signal)



The maximum length of the connecting cables of the PWM analog output is 1 m (3

280 ft); the one of the connecting cables of the 0-20 mA / 4-20 mA / 0-10 V analog outputs is instead of 30 m (98 ft).

For the settings about the analog outputs look at chapter 6 "CONFIGURATION".

The analog output 1 is usable on condition that the controller is powered in alternate current and the phase powering the controller is the same powering the user driven by the output.

#### ANALOG INPUTS/OUTPUTS (in c-pro 3 hecto+ only)

Analog inputs and analog outputs.

Terminal	Meaning
AI4	analog input 4 (NTC probes)
AO1	analog output 1 (PWM signal)
GND	ground
AO2	analog output 2 (configurable via configuration parameter for 0-20 mA / 4-20 mA / 0-10 V signal)
AO3	analog output 3 (configurable via configuration parameter for 0-20 mA / 4-20 mA / 0-10 V signal)



The maximum length of the connecting cables of the PWM analog output is 1 m (3.280 ft); the one of the connecting cables of the 0-20 mA / 4-20 mA / 0-10 V analog outputs is instead of 30 m (98 ft).

For the settings about the analog outputs look at chapter 6 "CONFIGURATION".

The analog output 1 is usable on condition that the controller is powered in alternate current and the phase powering the controller is the same powering the user driven by the output.

The analog output 1 and the analog output 2 are not independent each other but they work in the same way.

## DIGITAL INPUTS

Free of voltage digital inputs.

Terminal	Meaning
COM	common digital inputs
DI1	digital input 1
DI2	digital input 2
DI3	digital input 3
DI4	digital input 4
DI5	digital input 5



The maximum length of the connecting cables of the digital inputs is 100 m (328 ft).

## ANALOG INPUTS

Analog inputs.

Each analog input is configurable via configuration parameter for PTC / NTC / Pt 1000 probes / 0-20 mA / 4-20 mA / 0-5 V ratiometric / 0-10 V transducers.

Terminal	Meaning
AI1	analog input 1
AI2	analog input 2
AI3	analog input 3
GND	ground
+5V	power supply 0-5 V ratiometric transducers (5 VDC, 40 mA max.)
+24V	power supply 0-20 mA / 4-20 mA / 0-10 V transducers (24 VDC, 120 mA max.)



The maximum length of the connecting cables of the analog inputs and the one of the power supply of the transducers is 100 m (328 ft).

The controller incorporates a restorable thermal protection of the power supplies against the short circuit and the overload.

For the settings about the analog inputs look at chapter 6 "CONFIGURATION".

## PROG

Programming and debugging port.

**POWER SUPPLY**

Power supply.

Terminal	Meaning
V≡	power supply controller (24 VAC / 20... 40 VDC)
V≡	power supply controller (24 VAC / 20... 40 VDC)



The maximum length of the connecting cables of the power supply of the controller is 30 m (98 ft).

Protect the power supply with a fuse rated 0.8A-T 250 V.

If the controller is powered in direct current, one will not have to respect the polarity of the power supply voltage.

### 4.1.2. Example of electrical connection of c-pro 3 hecto

The following shows an example of electrical connection of c-pro 3 hecto.

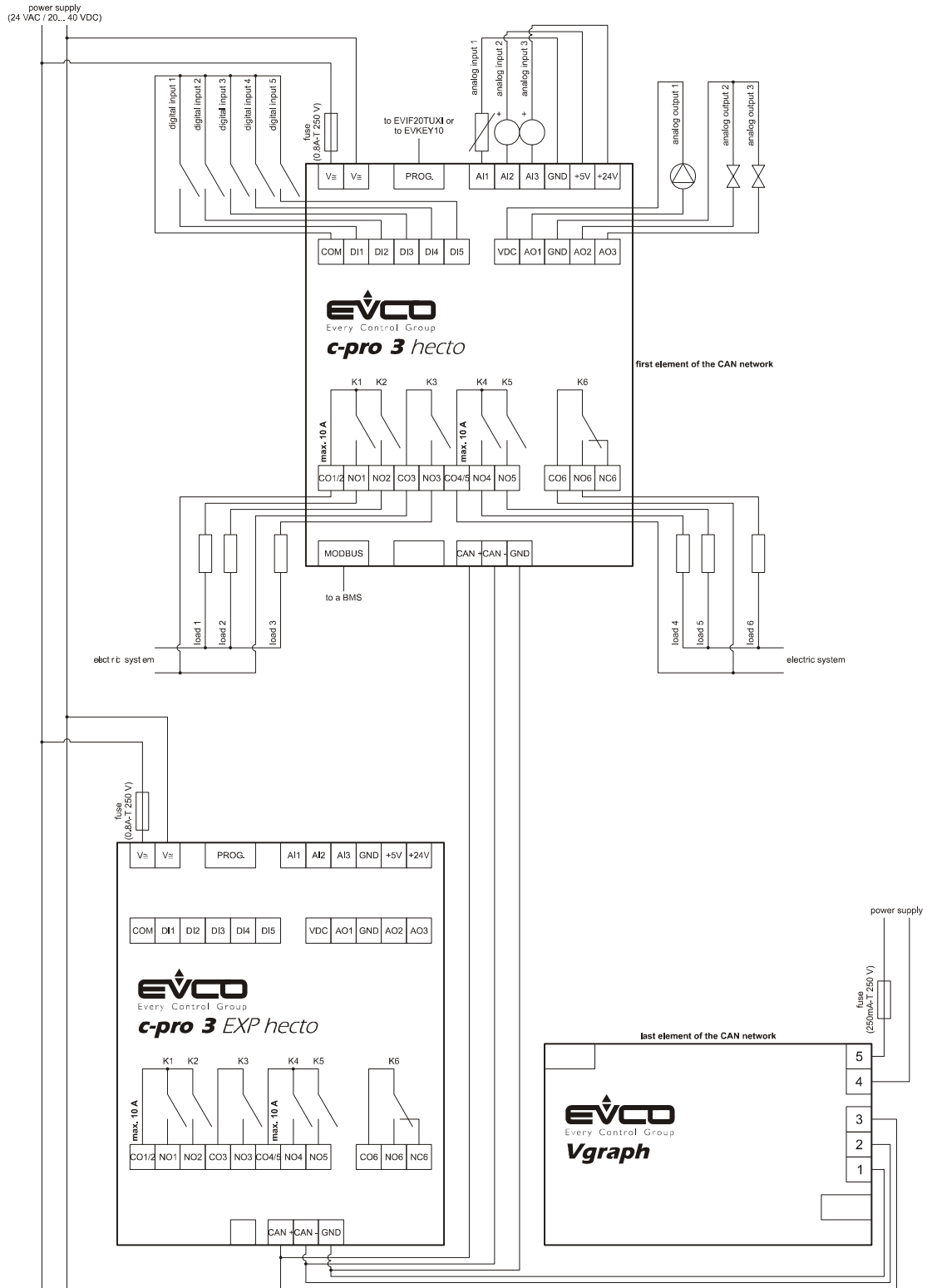

To reduce the reflections on the signal transmitted through the cables connecting the devices each other, plug in the termination of the CAN port of the first and of the last element of the network.



## 4.2. Electrical connection c-pro 3 mega and c-pro 3 NODE mega

### 4.2.1. Meaning of the connectors of c-pro 3 mega and of c-pro 3 NODE mega

The following drawing shows the connectors of **c-pro 3 mega** and of **c-pro 3 NODE mega**.

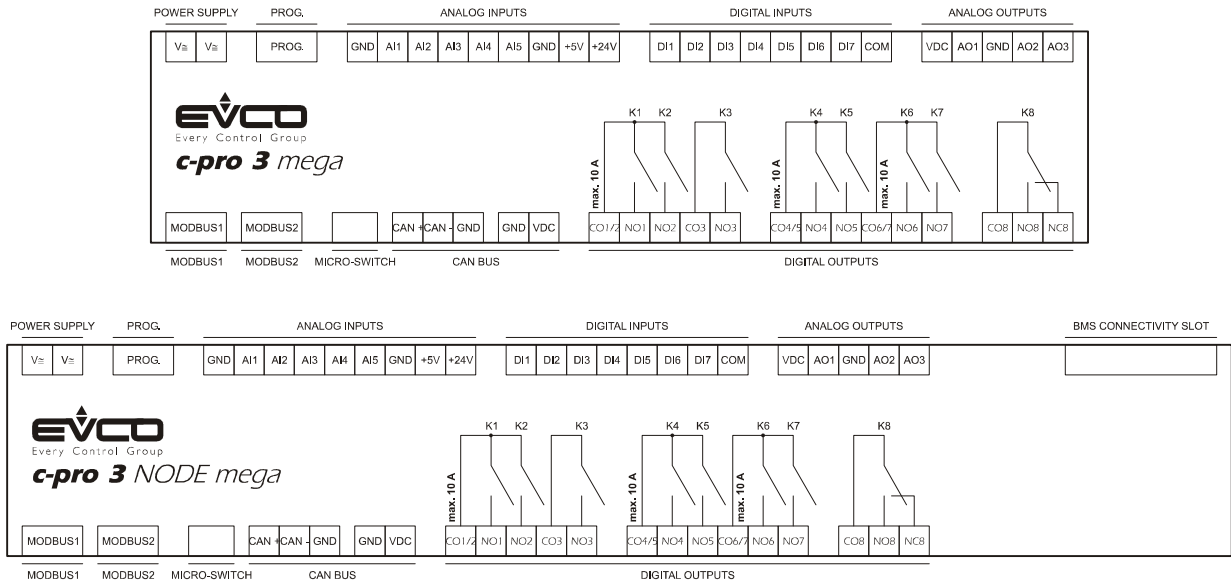

The following tables show the meaning of the connectors.

#### MODBUS1

RS-485 port with Modbus slave communication protocol.

The following drawing shows the aspect of the RS-485 port.

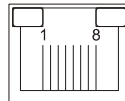

The following table shows the meaning of the pins of the RS-485 port.

Pin	Meaning
1	common
2	not connected
3	not connected
4	D0 = B = - (terminal 0 of the transceiver)
5	D1 = A = + (terminale 1 of the transceiver)
6	not connected
7	not connected

8 | not connected



The maximum length of the connecting cables of the RS-485 port is 1,000 m (3,280 ft); also look at the *Modbus specifications and implementation guides manual* (the document is available on the internet site [www.modbus.org](http://www.modbus.org)).

Connect the RS-485 port using a twisted pair.

The following table shows the *function codes* supported by the controller.

Function code	Meaning
FC 01	read coils
FC 02	read discrete inputs
FC 03	read multiple registers
FC 04	read input registers
FC 05	write single coil
FC 06	write single register
FC 08	diagnostic
FC 15	write multiple coils
FC 16	write multiple registers
FC 23	read write multiple registers

For the settings about the RS-485 port look at chapter 6 “CONFIGURATION”.

**MODBUS2**

RS-485 port with Modbus master / slave communication protocol (configurable via application software).

The following drawing shows the aspect of the RS-485 port.

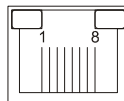

The following table shows the meaning of the pins of the RS-485 port.

Pin	Meaning
1	common
2	not connected

3	not connected
4	D0 = B = - (terminal 0 of the transceiver)
5	D1 = A = + (terminale 1 of the transceiver)
6	not connected
7	not connected
8	not connected



The maximum length of the connecting cables of the RS-485 port is 1,000 m (3,280 ft); also look at the *Modbus specifications and implementation guides manual* (the document is available on the internet site [www.modbus.org](http://www.modbus.org)).

Connect the RS-485 port using a twisted pair.

The following table shows the *function codes* supported by the controller.

Function code	Meaning
FC 01	read coils
FC 02	read discrete inputs
FC 03	read multiple registers
FC 04	read input registers
FC 05	write single coil
FC 06	write single register
FC 08	diagnostic
FC 15	write multiple coils
FC 16	write multiple registers
FC 23	read write multiple registers

For the settings about the RS-485 port look at chapter 6 “CONFIGURATION”.

**MICRO-SWITCH**

Micro-switch to:

- plug in the terminations of the RS-485 ports (120 Ω, 0.25 W); position micro-switch 1 on position ON to plug in the termination of the first RS-485 port and micro-switch 2 on position ON to plug in the termination of the second RS-485 port (plug in the termination of the first and of the last element of the network)



- polarize the network of the second RS-485 port (560 Ω, 0.25 W); position micro-switches 3 and 4 on position ON to polarize the network of the second RS-485 port (the network must be polarized by an element of the network same).

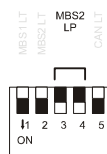

- plug in the termination of the CAN port (120 Ω, 0.5 W); position micro-switch 4 on position ON to plug in the termination of the CAN port (plug in the termination of the first and of the last element of the network).



**CAN BUS**

CAN port.

Terminal	Meaning
CAN +	signal +
CAN -	signal -
GND	ground

The maximum number of devices that can make a CAN network (32) depends on the bus load; the bus load depends on the baud rate of the CANbus communication and on the kind of device in the network.



For example: a CAN network can be made of a programmable controller, of four I / O expansions and of four user interfaces with baud rate 500,000 baud.



The maximum length of the connecting cables of the CAN port depends on the baud rate of the CANbus communication, as follows:

- 1,000 m (3,280 ft) with baud rate 20,000 baud
- 500 m (1,640 ft) with baud rate 50,000 baud
- 250 m (820 ft) with baud rate 125,000 baud
- 50 m (164 ft) with baud rate 500,000 baud.

Connect the CAN port using a twisted pair.

For the settings about the CAN port look at chapter 6 "CONFIGURATION".

Power supply user interface.

Terminal	Meaning
GND	ground
VDC	power supply user interface (24 VDC, 120 mA max.)



The maximum length of the connecting cables of the power supply of the user interface is 30 m (98 ft).

The controller incorporates a restorable thermal protection of the power supplies against the short circuit and the overload.

### DIGITAL OUTPUTS

Digital outputs 1, 2 and 3 (electromechanical relays).

Terminal	Meaning
CO1/2	common digital outputs 1 and 2
NO1	normally open contact digital output 1
NO2	normally open contact digital output 2
CO3	common digital output 3
NO3	normally open contact digital output 3

Digital outputs 4, 5, 6 e 7 (electromechanical relays).

Terminal	Meaning
CO4/5	common digital outputs 4 and 5
NO4	normally open contact digital output 4
NO5	normally open contact digital output 5
CO6/7	common digital outputs 6 and 7
NO6	normally open contact digital output 6
NO7	normally open contact digital output 7

Digital output 8 (electromechanical relay).

Terminal	Meaning
CO8	common digital output 8

NO8	normally open contact digital output 8
NC8	normally closed contact digital output 8



The maximum length of the connecting cables of the digital outputs is 100 m (328 ft).

The maximum current allowed on the loads is 10 A.

#### **BMS CONNECTIVITY SLOT (in c-pro 3 NODE mega only)**

Slot for gateway *c-pro 3 plug-in*; also look at the User guide of *c-pro 3 plug-in*.

#### **ANALOG OUTPUTS**

Analog outputs.

Terminal	Meaning
VDC	power supply driving analog output 1 (24 VDC, 50 mA max.)
AO1	analog output 1 (PWM signal)
GND	ground
AO2	analog output 2 (configurable via configuration parameter for 0-20 mA / 4-20 mA / 0-10 V signal)
AO3	analog output 3 (configurable via configuration parameter for 0-20 mA / 4-20 mA / 0-10 V signal)



The maximum length of the connecting cables of the PWM analog output is 1 m (3.280 ft); the one of the connecting cables of the 0-20 mA / 4-20 mA / 0-10 V analog outputs is instead of 30 m (98 ft).

For the settings about the analog outputs look at chapter 6 "CONFIGURATION".

The analog output 1 is usable on condition that the controller is powered in alternate current and the phase powering the controller is the same powering the user driven by the output.

#### **DIGITAL INPUTS**

Digital inputs.

Terminal	Meaning
DI1	digital input 1
DI2	digital input 2
DI3	digital input 3
DI4	digital input 4
DI5	digital input 5
DI6	digital input 6

DI7	digital input 7
COM	common digital inputs



The maximum length of the connecting cables of the digital inputs is 100 m (328 ft).

The digital inputs can be used on condition that they are powered at 24 VAC / DC.

## ANALOG INPUTS

Analog inputs.

Each analog input is configurable via configuration parameter for PTC / NTC / Pt 1000 probes / 0-20 mA / 4-20 mA / 0-5 V ratiometric / 0-10 V transducers.

Terminal	Meaning
GND	ground
AI1	analog input 1
AI2	analog input 2
AI3	analog input 3
AI4	analog input 4
AI5	analog input 5
GND	ground
+5V	power supply 0-5 V ratiometric transducers (5 VDC, 40 mA max.)
+24V	power supply 0-20 mA / 4-20 mA / 0-10 V transducers (24 VDC, 120 mA max.)



The maximum length of the connecting cables of the analog inputs and the one of the power supply of the transducers is 100 m (328 ft).

The controller incorporates a restorable thermal protection of the power supplies against the short circuit and the overload.

For the settings about the analog inputs look at chapter 6 "CONFIGURATION".

## PROG

Programming and debugging port.

## POWER SUPPLY

Power supply.

Terminal	Meaning
V≡	power supply controller (24 VAC / 20... 40 VDC)
V≡	power supply controller (24 VAC / 20... 40 VDC)



The maximum length of the connecting cables of the power supply of the controller is 30 m (98 ft).

Protect the power supply with a fuse rated 2.5A-T 250 V.

If the controller is powered in direct current, one will not have to respect the polarity of the power supply voltage.



### 4.2.2. Example of electrical connection of c-pro 3 mega

The following drawing shows an example of electrical connection of c-pro 3 mega.

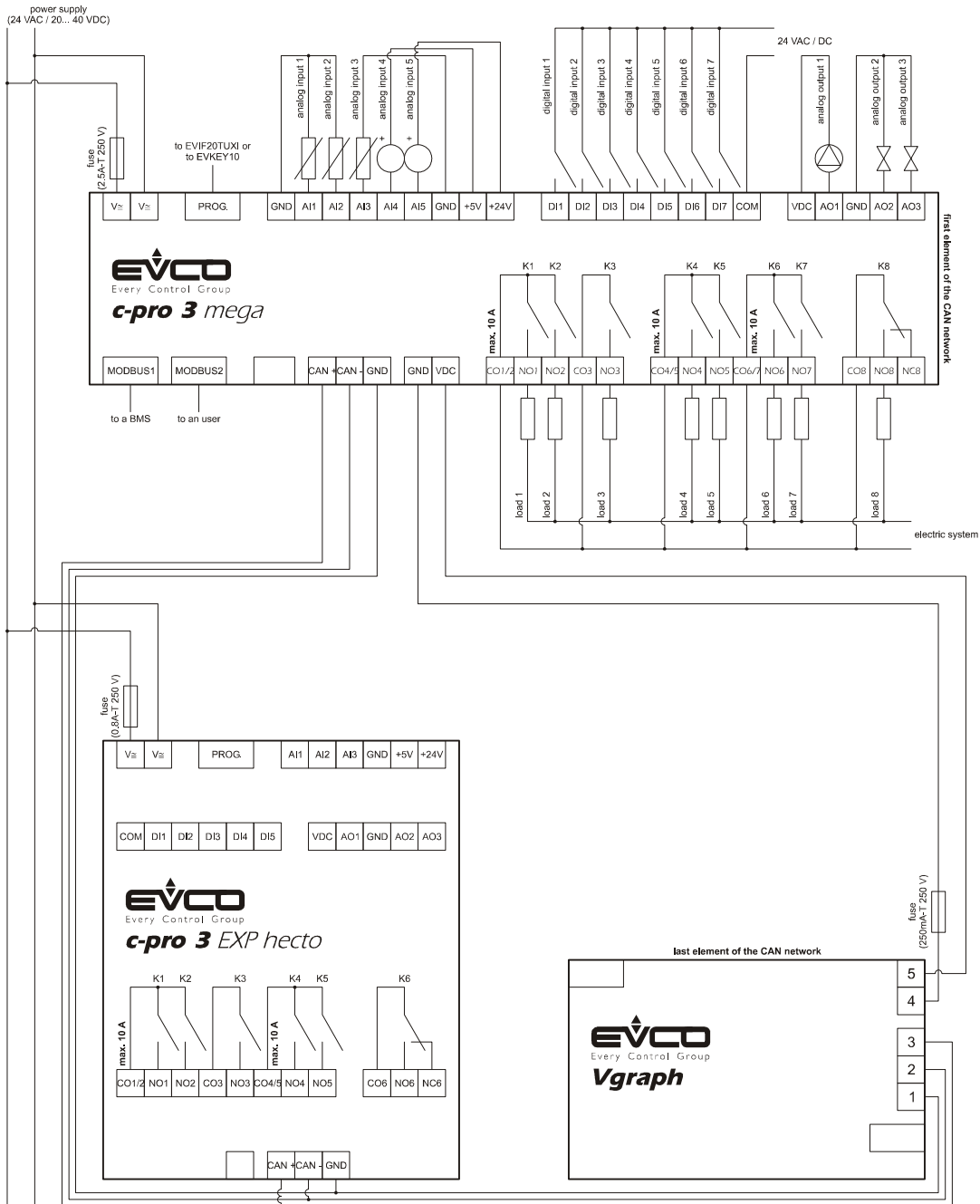

To reduce the reflections on the signal transmitted through the cables connecting the devices each other, plug in the termination of the CAN port of the first and of the last element of the network.

### 4.3. Electrical connection c-pro 3 mega+

#### 4.3.1. Meaning of the connectors of c-pro 3 mega+

The following drawing shows the connectors of c-pro 3 mega+.

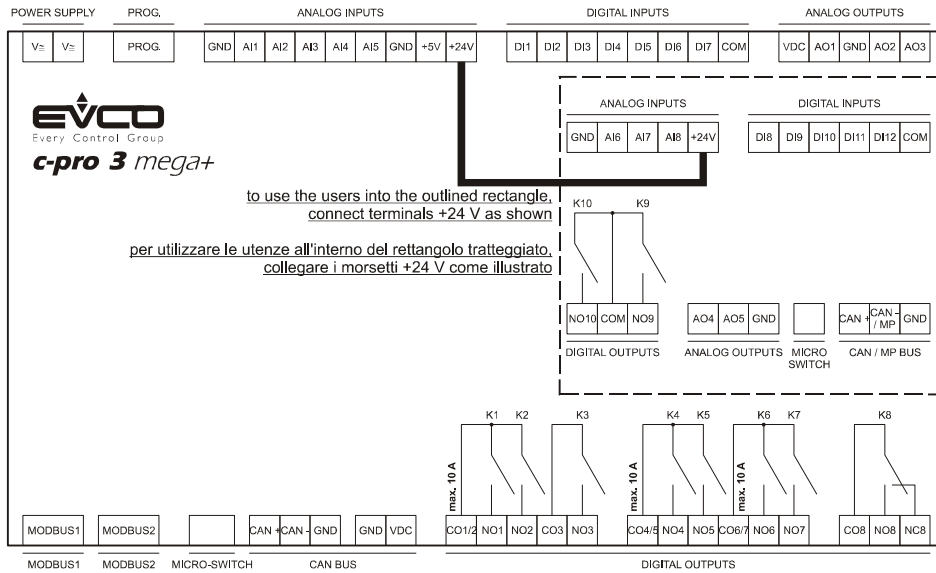

The following tables show the meaning of the connectors.

#### MODBUS1

RS-485 port with Modbus slave communication protocol.

The following drawing shows the aspect of the RS-485 port.

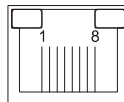

The following table shows the meaning of the pins of the RS-485 port.

Pin	Meaning
1	common
2	not connected
3	not connected
4	D0 = B = - (terminal 0 of the transceiver)
5	D1 = A = + (terminale 1 of the transceiver)
6	not connected
7	not connected

8 | not connected



The maximum length of the connecting cables of the RS-485 port is 1,000 m (3,280 ft); also look at the *Modbus specifications and implementation guides manual* (the document is available on the internet site [www.modbus.org](http://www.modbus.org)).

Connect the RS-485 port using a twisted pair.

The following table shows the *function codes* supported by the controller.

Function code	Meaning
FC 01	read coils
FC 02	read discrete inputs
FC 03	read multiple registers
FC 04	read input registers
FC 05	write single coil
FC 06	write single register
FC 08	diagnostic
FC 15	write multiple coils
FC 16	write multiple registers
FC 23	read write multiple registers

For the settings about the RS-485 port look at chapter 6 "CONFIGURATION".

## MODBUS2

RS-485 port with Modbus master / slave communication protocol (configurable via application software).

The following drawing shows the aspect of the RS-485 port.

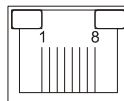

The following table shows the meaning of the pins of the RS-485 port.

Pin	Meaning
1	common
2	not connected

3	not connected
4	D0 = B = - (terminal 0 of the transceiver)
5	D1 = A = + (terminale 1 of the transceiver)
6	not connected
7	not connected
8	not connected



The maximum length of the connecting cables of the RS-485 port is 1,000 m (3,280 ft); also look at the *Modbus specifications and implementation guides manual* (the document is available on the internet site [www.modbus.org](http://www.modbus.org)).

Connect the RS-485 port using a twisted pair.

The following table shows the *function codes* supported by the controller.

Function code	Meaning
FC 01	read coils
FC 02	read discrete inputs
FC 03	read multiple registers
FC 04	read input registers
FC 05	write single coil
FC 06	write single register
FC 08	diagnostic
FC 15	write multiple coils
FC 16	write multiple registers
FC 23	read write multiple registers

For the settings about the RS-485 port look at chapter 6 “CONFIGURATION”.

**MICRO-SWITCH**

Micro-switch to:

- plug in the terminations of the RS-485 ports (120 Ω, 0.25 W); position micro-switch 1 on position ON to plug in the termination of the first RS-485 port and micro-switch 2 on position ON to plug in the termination of the second RS-485 port (plug in the termination of the first and of the last element of the network)



- polarize the network of the second RS-485 port (560 Ω, 0.25 W); position micro-switches 3 and 4 on position ON to polarize the network of the second RS-485 port (the network must be polarized by an element of the network same).



- plug in the termination of the first CAN port (120 Ω, 0.5 W); position micro-switch 4 on position ON to plug in the termination of the CAN port (plug in the termination of the first and of the last element of the network).



**CAN BUS**

First CAN port.

Terminal	Meaning
CAN +	signal +
CAN -	signal -
GND	ground

The maximum number of devices that can make a CAN network (32) depends on the bus load; the bus load depends on the baud rate of the CANbus communication and on the kind of device in the network.



For example: a CAN network can be made of a programmable controller, of four I / O expansions and of four user interfaces with baud rate 500,000 baud.



The maximum length of the connecting cables of the CAN port depends on the baud rate of the CANbus communication, as follows:

- 1,000 m (3,280 ft) with baud rate 20,000 baud
- 500 m (1,640 ft) with baud rate 50,000 baud
- 250 m (820 ft) with baud rate 125,000 baud
- 50 m (164 ft) with baud rate 500,000 baud.

Connect the CAN port using a twisted pair.

For the settings about the CAN port look at chapter 6 "CONFIGURATION".

Power supply user interface.

Terminal	Meaning
GND	ground
VDC	power supply user interface (24 VDC, 120 mA max.)



The maximum length of the connecting cables of the power supply of the user interface is 30 m (98 ft).

The controller incorporates a restorable thermal protection of the power supplies against the short circuit and the overload.

### DIGITAL OUTPUTS

Digital outputs 1, 2 and 3 (electromechanical relays).

Terminal	Meaning
CO1/2	common digital outputs 1 and 2
NO1	normally open contact digital output 1
NO2	normally open contact digital output 2
CO3	common digital output 3
NO3	normally open contact digital output 3

Digital outputs 4, 5, 6 e 7 (electromechanical relays).

Terminal	Meaning
CO4/5	common digital outputs 4 and 5
NO4	normally open contact digital output 4
NO5	normally open contact digital output 5
CO6/7	common digital outputs 6 and 7
NO6	normally open contact digital output 6
NO7	normally open contact digital output 7

Digital output 8 (electromechanical relay).

Terminal	Meaning
CO8	common digital output 8

NO8	normally open contact digital output 8
NC8	normally closed contact digital output 8



The maximum length of the connecting cables of the digital outputs is 100 m (328 ft).

The maximum current allowed on the loads is 10 A.

### ANALOG OUTPUTS

Analog outputs 1, 2 and 3.

Terminal	Meaning
VDC	power supply driving analog output 1 (24 VDC, 50 mA max.)
AO1	analog output 1 (PWM signal)
GND	ground
AO2	analog output 2 (configurable via configuration parameter for 0-20 mA / 4-20 mA / 0-10 V signal)
AO3	analog output 3 (configurable via configuration parameter for 0-20 mA / 4-20 mA / 0-10 V signal)



The maximum length of the connecting cables of the PWM analog output is 1 m (3.280 ft); the one of the connecting cables of the 0-20 mA / 4-20 mA / 0-10 V analog outputs is instead of 30 m (98 ft).

For the settings about the analog outputs look at chapter 6 "CONFIGURATION".

The analog output 1 is usable on condition that the controller is powered in alternate current and the phase powering the controller is the same powering the user driven by the output.

### DIGITAL INPUTS

Digital inputs 1, 2, 3, 4, 5, 6 and 7.

Terminal	Meaning
DI1	digital input 1
DI2	digital input 2
DI3	digital input 3
DI4	digital input 4
DI5	digital input 5
DI6	digital input 6
DI7	digital input 7
COM	common digital inputs



The maximum length of the connecting cables of the digital inputs is 100 m (328 ft).

The digital inputs can be used on condition that they are powered at 24 VAC / DC.

### ANALOG INPUTS

Analog inputs 1, 2, 3, 4 and 5.

Each analog input is configurable via configuration parameter for PTC / NTC / NTC 2 / NTC 3 / Pt 1000 probes / 0-20 mA / 4-20 mA / 0-5 V ratiometric / 0-10 V transducers, but the analog input 2 of the models with second CAN port which is configurable via configuration parameter for PTC / NTC / NTC 2 / NTC 3 / Pt 1000 probes.

Terminal	Meaning
GND	ground
AI1	analog input 1
AI2	analog input 2
AI3	analog input 3
AI4	analog input 4
AI5	analog input 5
GND	ground
+5V	power supply 0-5 V ratiometric transducers (5 VDC, 40 mA max.)
+24V	power supply 0-20 mA / 4-20 mA / 0-10 V transducers (24 VDC, 120 mA max.)



The maximum length of the connecting cables of the analog inputs and the one of the power supply of the transducers is 100 m (328 ft).

The controller incorporates a restorable thermal protection of the power supplies against the short circuit and the overload.

For the settings about the analog inputs look at chapter 6 "CONFIGURATION".

### PROG

Programming and debugging port.

### POWER SUPPLY

Power supply.

Terminal	Meaning
V≡	power supply controller (24 VAC / 20... 40 VDC)
V≡	power supply controller (24 VAC / 20... 40 VDC)



The maximum length of the connecting cables of the power supply of the controller is 30 m (98 ft).

Protect the power supply with a fuse rated 2.5A-T 250 V.

If the controller is powered in direct current, one will not have to respect the polarity of the power supply voltage.



**DIGITAL OUTPUTS**

Digital outputs 9 and 10 (electromechanical relays).

Terminal	Meaning
NO10	normally open contact digital output 10
COM	common digital outputs 9 and 10
NO9	normally open contact digital output 9



The maximum length of the connecting cables of the digital outputs is 10 m (32 ft).

The maximum current allowed on the loads is 10 A.

**ANALOG OUTPUTS**

Analog outputs 4 and 5.

Terminal	Meaning
AO4	analog output 4 (configurable via configuration parameter for PWM / 0-10 V signal)
AO5	analog output 5 (configurable via configuration parameter for PWM / 0-10 V signal)



The maximum length of the connecting cables of the PWM analog output is 1 m (3.280 ft); the one of the connecting cables of the 0-10 V analog outputs is instead of 10 m (32 ft).

For the settings about the analog outputs look at chapter 6 "CONFIGURATION".

**MICRO-SWITCH**

Micro-switch to plug in the termination of the second CAN port (120  $\Omega$ , 0.5 W); position micro-switch 1 on position ON to plug in the termination of the second CAN port (plug in the termination of the first and of the last element of the network).

**CAN BUS / MP BUS**

For the models with second CAN port the connectors have the following meaning.

Terminal	Meaning
CAN +	signal +
CAN - / MP	signal -
GND	ground

The maximum number of devices that can make a CAN network (32) depends on the bus load; the bus load depends on the baud rate of the CANbus communication and on the kind of device in the network.



For example: a CAN network can be made of a programmable controller, of four I / O expansions and of four user interfaces with baud rate 500,000 baud.



The maximum length of the connecting cables of the CAN port depends on the baud rate of the CANbus communication, as follows:

- 1,000 m (3,280 ft) with baud rate 20,000 baud
- 500 m (1,640 ft) with baud rate 50,000 baud
- 250 m (820 ft) with baud rate 125,000 baud
- 50 m (164 ft) with baud rate 500,000 baud.

Connect the CAN port using a twisted pair.

For the settings about the CAN port look at chapter 6 "CONFIGURATION".

For the models with MP-Bus port the connectors have the following meaning.

Terminal	Meaning
CAN +	not connected
CAN - / MP	signal
GND	ground

The maximum number of devices that can make a MP-Bus network is 8.

To the MP-Bus port can be connected the Belimo's devices that manage correctly the commands *MP\_Get\_SeriesNo*, *MP\_Set\_MP\_Address* (that allow the configuration of the network) and *MP\_Set\_Relative* (that allows to drive the position of the actuator).

If you want to connect a probe (or a relay) to the actuator, the device must also manage the commands *MP\_AD\_Convert* (that allows to read the probe value) and/or *MP\_Get\_Forced\_Control* (that allows to read the relay status).



The maximum length of the connecting cables of the MP-Bus port is 10 m (32 ft).

Connect the CAN port using a twisted pair.

For the settings about the CAN port look at chapter 6 "CONFIGURATION".

## DIGITAL INPUTS

Digital inputs 8, 9, 10, 11 and 12.

Terminal	Meaning
DI8	digital input 8
DI9	digital input 9
DI10	digital input 10
DI11	digital input 11
DI12	digital input 12
COM	common digital inputs



The maximum length of the connecting cables of the digital inputs is 10 m (32 ft).

The digital inputs can be used on condition that they are powered at 24 VAC / DC.

**ANALOG INPUTS**

Analog inputs 6, 7 and 8.

Each analog input is configurable via configuration parameter for NTC / 0-20 mA / 4-20 mA transducers.

Terminal	Meaning
GND	ground
AI6	analog input 6
AI7	analog input 7
AI8	analog input 8
+24V	power supply 0-20 mA / 4-20 mA transducers (24 VDC, 120 mA max.)



The maximum length of the connecting cables of the analog inputs and the one of the power supply of the transducers is 10 m (32 ft).

The controller incorporates a restorable thermal protection of the power supplies against the short circuit and the overload.

For the settings about the analog inputs look at chapter 6 "CONFIGURATION".

### 4.3.2. Example of electrical connection of c-pro 3 mega+

The following drawing shows an example of electrical connection of c-pro 3 mega+.

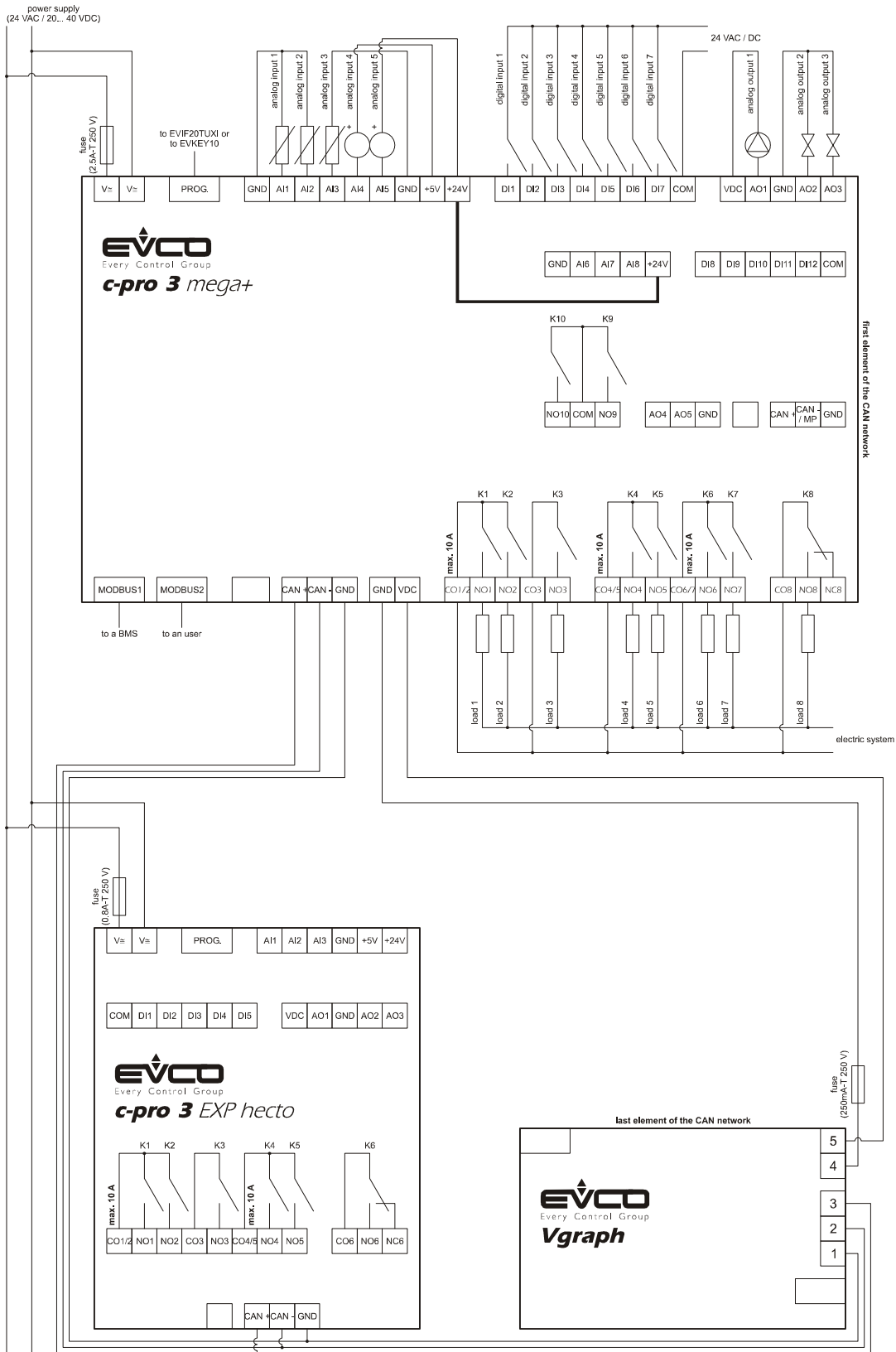

It continues in the following page.

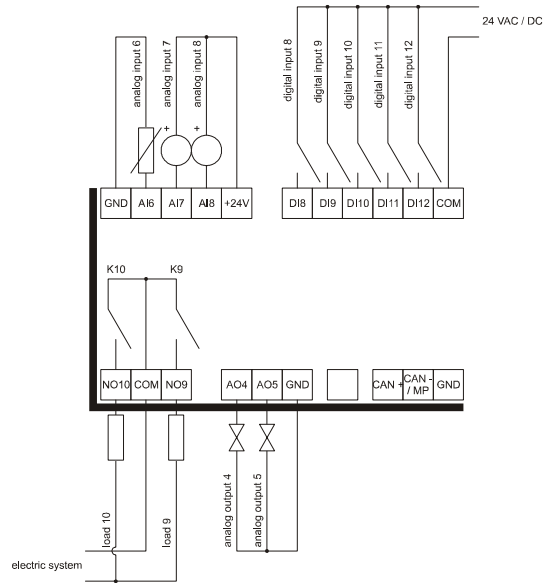

To reduce the reflections on the signal transmitted through the cables connecting the devices each other, plug in the termination of the CAN port of the first and of the last element of the network.

## 4.4. Electrical connection c-pro 3 EXP hecto and c-pro 3 EXP hecto+

### 4.4.1. Meaning of the connectors of c-pro 3 EXP hecto and of c-pro 3 EXP hecto+

The following drawing shows the connectors of **c-pro 3 EXP hecto** and of **c-pro 3 EXP hecto+**.

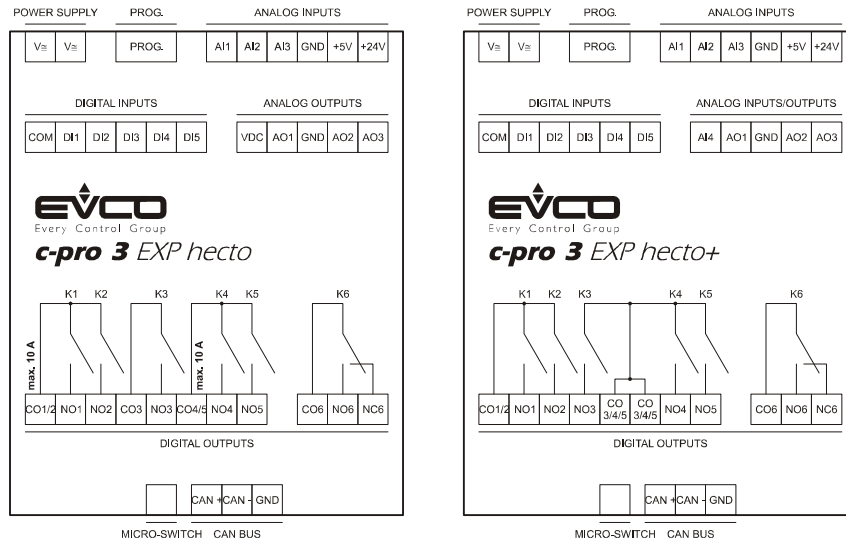

The following tables show the meaning of the connectors.

#### MICRO-SWITCH

Micro switch to plug in the termination of the CAN port (120 Ω, 0.5 W); position micro-switch 2 on position ON to plug in the termination of the CAN port (plug in the termination of the first and of the last element of the network).



#### CAN BUS

CAN port.

Terminal	Meaning
CAN +	signal +
CAN -	signal -
GND	ground

The maximum number of devices that can make a CAN network (32) depends on the bus load; the bus load depends on the baud rate of the CANbus communication and on the kind of device in the network.



For example: a CAN network can be made of a programmable controller, of four I / O expansions and of four user interfaces with baud rate 500,000 baud.



The maximum length of the connecting cables of the CAN port depends on the baud rate of the CANbus communication, as follows:

- 1,000 m (3,280 ft) with baud rate 20,000 baud
- 500 m (1,640 ft) with baud rate 50,000 baud
- 250 m (820 ft) with baud rate 125,000 baud
- 50 m (164 ft) with baud rate 500,000 baud.

Connect the CAN port using a twisted pair.

For the settings about the CAN port look at chapter 6 "CONFIGURATION".

## DIGITAL OUTPUTS

In **c-pro 3 EXP hecto**.

Digital outputs 1, 2, 3, 4 and 5 (electromechanical relays).

Terminal	Meaning
CO1/2	common digital outputs 1 and 2
NO1	normally open contact digital output 1
NO2	normally open contact digital output 2
CO3	common digital output 3
NO3	normally open contact digital output 3
CO4/5	common digital outputs 4 and 5
NO4	normally open contact digital output 4
NO5	normally open contact digital output 5

Digital output 6 (electromechanical relay).

Terminal	Meaning
CO6	common digital output 6
NO6	normally open contact digital output 6
NC6	normally closed contact digital output 6



The maximum length of the connecting cables of the digital outputs is 100 m (328 ft).

The maximum current allowed on the loads is 10 A.

**DIGITAL OUTPUTS**In **c-pro 3 EXP hecto+**.

Digital outputs 1, 2, 3, 4 and 5 (electromechanical relays).

Terminal	Meaning
CO1/2	common digital outputs 1 and 2
NO1	normally open contact digital output 1
NO2	normally open contact digital output 2
NO3	normally open contact digital output 3
CO3/4/5	common digital outputs 3, 4 and 5
CO3/4/5	common digital outputs 3, 4 and 5
NO4	normally open contact digital output 4
NO5	normally open contact digital output 5

Digital output 6 (electromechanical relay).

Terminal	Meaning
CO6	common digital output 6
NO6	normally open contact digital output 6
NC6	normally closed contact digital output 6



The maximum length of the connecting cables of the digital outputs is 100 m (328 ft).

**ANALOG OUTPUTS (in c-pro 3 EXP hecto only)**

Analog outputs.

Terminal	Meaning
VDC	power supply driving analog output 1 (24 VDC, 50 mA max.)
AO1	analog output 1 (PWM signal)
GND	ground
AO2	analog output 2 (configurable via configuration parameter for 0-20 mA / 4-20 mA / 0-10 V signal)
AO3	analog output 3 (configurable via configuration parameter for 0-20 mA / 4-20 mA / 0-10 V signal)





The maximum length of the connecting cables of the PWM analog output is 1 m (3.280 ft); the one of the connecting cables of the 0-20 mA / 4-20 mA / 0-10 V analog outputs is instead of 30 m (98 ft).

For the settings about the analog outputs look at chapter 6 "CONFIGURATION".

The analog output 1 is usable on condition that the expansion is powered in alternate current and the phase powering the controller is the same powering the user driven by the output.

#### ANALOG INPUTS/OUTPUTS (in c-pro 3 EXP hecto+ only)

Analog inputs and analog outputs.

Terminal	Meaning
AI4	analog input 4 (NTC probes)
AO1	analog output 1 (PWM signal)
GND	ground
AO2	analog output 2 (configurable via configuration parameter for 0-20 mA / 4-20 mA / 0-10 V signal)
AO3	analog output 3 (configurable via configuration parameter for 0-20 mA / 4-20 mA / 0-10 V signal)



The maximum length of the connecting cables of the PWM analog output is 1 m (3.280 ft); the one of the connecting cables of the 0-20 mA / 4-20 mA / 0-10 V analog outputs is instead of 30 m (98 ft).

For the settings about the analog outputs look at chapter 6 "CONFIGURATION".

The analog output 1 is usable on condition that the expansion is powered in alternate current and the phase powering the controller is the same powering the user driven by the output.

The analog output 1 and the analog output 2 are not independent each other but they work in the same way.

#### DIGITAL INPUTS

Free of voltage digital inputs.

Terminal	Meaning
COM	common digital inputs
DI1	digital input 1
DI2	digital input 2
DI3	digital input 3
DI4	digital input 4
DI5	digital input 5



The maximum length of the connecting cables of the digital inputs is 100 m (328 ft).

## ANALOG INPUTS

Analog inputs.

Each analog input is configurable via configuration parameter for PTC / NTC / Pt 1000 probes / 0-20 mA / 4-20 mA / 0-5 V ratiometric / 0-10 V transducers.

Terminal	Meaning
AI1	analog input 1
AI2	analog input 2
AI3	analog input 3
GND	ground
+5V	power supply 0-5 V ratiometric transducers (5 VDC, 40 mA max.)
+24V	power supply 0-20 mA / 4-20 mA / 0-10 V transducers (24 VDC, 120 mA max.)



The maximum length of the connecting cables of the analog inputs and the one of the power supply of the transducers is 100 m (328 ft).

The expansion incorporates a restorable thermal protection of the power supplies against the short circuit and the overload.

For the settings about the analog inputs look at chapter 6 "CONFIGURATION".

## PROG

Port to update the firmware of the instrument.

## POWER SUPPLY

Power supply.

Terminal	Meaning
V≡	power supply expansion (24 VAC / 20... 40 VDC)
V≡	power supply expansion (24 VAC / 20... 40 VDC)



The maximum length of the connecting cables of the power supply of the expansion is 30 m (98 ft).

Protect the power supply with a fuse rated 0.8A-T 250 V.

If the expansion is powered in direct current, one will not have to respect the polarity of the power supply voltage.

### 4.4.2. Example of electrical connection of c-pro 3 EXP hecto

The following drawing shows an example of electrical connection of c-pro 3 EXP hecto.

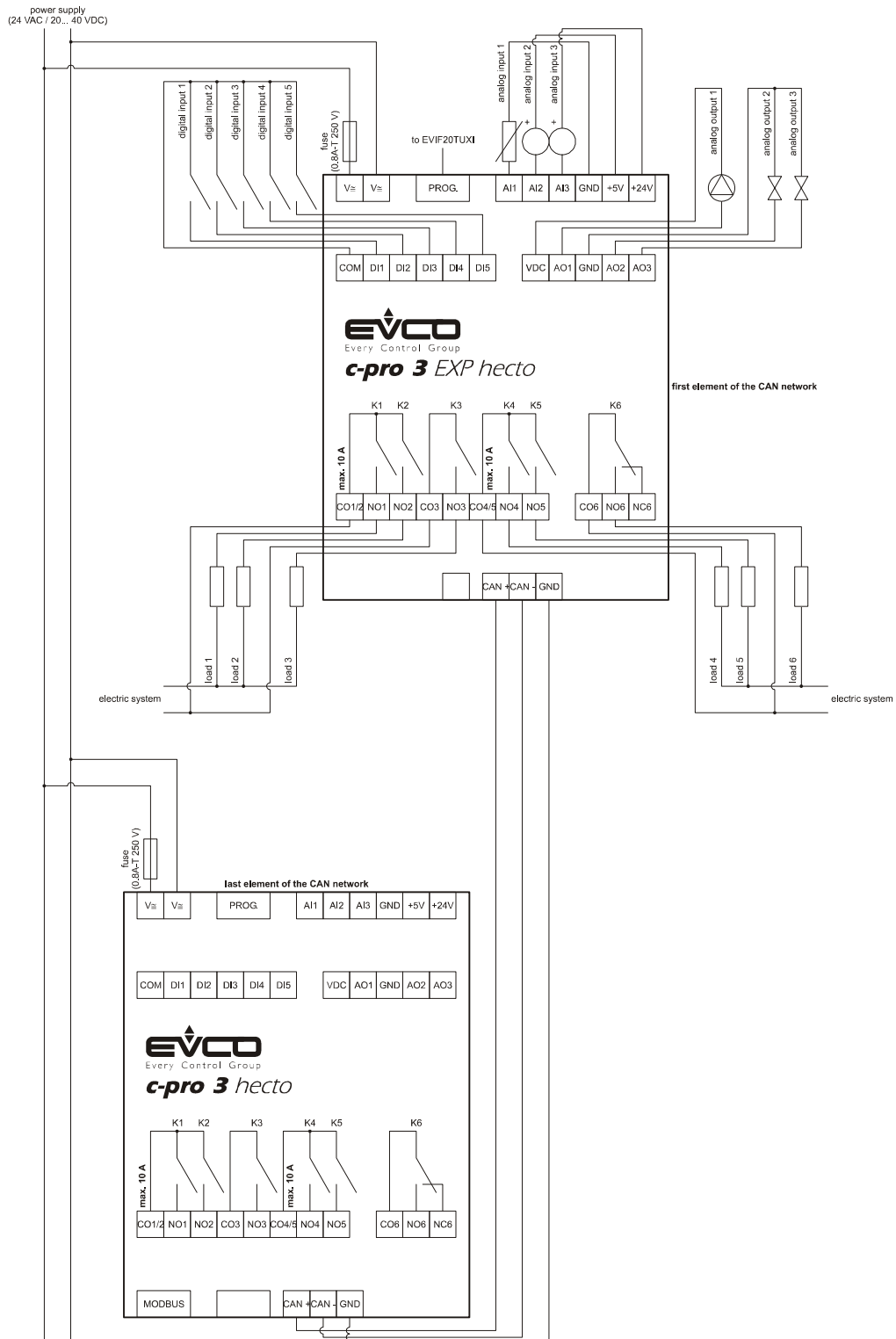

To reduce the reflections on the signal transmitted through the cables connecting the devices each other, plug in the termination of the CAN port of the first and of the last element of the network.







## 4.5. Additional information for electrical connection

- do not operate on the terminal blocks with electrical or pneumatic screwdrivers
- if the device has been moved from a cold location to a warm one, the humidity could condense on the inside; wait about an hour before powering it
- test the working power supply voltage, working electrical frequency and working electrical power of the controller; they must correspond with the local power supply
- connect the device to the other devices using a twisted pair
- disconnect the local power supply before servicing the device
- do not use the device as safety device
- for repairs and information on the device please contact the EVCO's sales network.

## 5. USER INTERFACE

### 5.1. Keyboard

The following table shows the meaning of the keyboard.

Button	Preset function
	cancel, hereinafter also called "button ESC"
	move to left, hereinafter also called "button LEFT"
	increase, hereinafter also called "button UP"
	decrease, hereinafter also called "button DOWN"
	move to right, hereinafter also called "button RIGHT"
	confirmation, hereinafter also called "button ENTER"

The keyboard is not available in the blind versions.

### 5.2. Signalling LEDs

#### 5.2.1. LEDs at the front of the device

The following table shows the meaning of the LEDs at the front of the device.

LED	Meaning
ON	LED power supply if it is lit, the device will be powered if it is out, the device will not be powered
RUN	LED run if it is lit, the application software will be compiled and running in <i>release</i> modality if it flashes slowly, the application software will be compiled and running in <i>debug</i> modality (condition not allowed in <b>c-pro 3 EXP hecto</b> and in in <b>c-pro 3 EXP hecto+</b> ) if it flashes quickly, the application software will be compiled, running in <i>debug</i> modality and stopped in a <i>breakpoint</i> (condition not allowed in <b>c-pro 3 EXP hecto</b> and in in <b>c-pro 3 EXP hecto+</b> ) if it is out (condition not allowed in <b>c-pro 3 EXP hecto</b> and in in <b>c-pro 3 EXP hecto+</b> ): - the controller will not be compatible with the application software - the controller will not be enabled to work with the <i>Special ABL (Application Block Libraries)</i>
	LED system alarm if it is lit, an alarm system not restorable via software will be running if it flashes slowly, a system alarm with automatic reset will be running if it flashes quickly, a system alarm with manual reset will be running if it is out, no alarm system will be running

<b>CAN</b>	<p>LED CANbus communication</p> <p>if it is lit, the device will be configured to communicate via CANbus with another device but the CAN communication will not have been set up</p> <p>if it flashes slowly, the CANbus communication will have been set up but it will not be completely correct</p> <p>if it flashes quickly, the CANbus communication will have been set up and will be correct</p> <p>if it is out, no CANbus communication will be running</p>
<b>L1</b>	<p>LED auxiliary (not used in <b>c-pro 3 hecto</b>, in <b>c-pro 3 hecto+</b>, in <b>c-pro 3 EXP hecto</b> and in <b>c-pro 3 EXP hecto</b>)</p> <p>The operation of this LED can be programmed through the development environment UNI-PRO 3</p>

### 5.2.2. LEDs on the RS-485 ports

The following drawing shows the aspect of a RS-485 port.

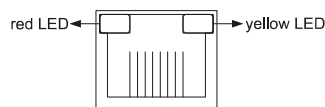

The following table shows the meaning of the LEDs on the RS-485 ports.

LED	Meaning
<b>red LED</b>	<p>LED error</p> <p>if it is lit, an internal error will have arisen</p> <p>if it flashes quickly, a configuration error will have arisen</p> <p>if it is out, no error will be running</p>
<b>yellow LED</b>	<p>LED Modbus communication</p> <p>if it is lit, no Modbus communication will be running</p> <p>if it flashes quickly, the Modbus communication will have been set up and will be correct</p> <p>if it is out, the controller will not be configured to communicate via Modbus</p>

## 6. CONFIGURATION

### 6.1. Configuring a programmable controller

#### 6.1.1. Configuring a built-in programmable controller

To gain access to the procedure operate as follows:

1. Make sure the power supply is switched on.
2. Keep pressed 2 s buttons UP and DOWN: the display will show the following menu (hereinafter called *Main menu*).

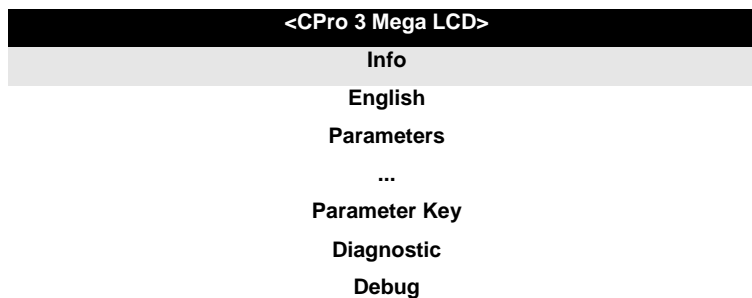

It is also possible to configure the controller using an user interface; look at paragraph 6.3 “Configuring a device through an user interface”.

To gain access to a submenu operate as follows:

3. Press and release button UP or button DOWN to select the submenu.
4. Press and release button ENTER.



The access to the *Parameters* submenu, to the *Networks* submenu, to the *Password* submenu and to the *Parameter Key* submenu is protected by password.

To gain access to the *Parameters* submenu, to the *Networks* submenu, to the *Password* submenu and to the *Parameter Key* submenu operate as follows:

5. From step 2, press and release button UP or button DOWN to select the submenu.
6. Press and release button ENTER.
7. Press and release button ENTER again to set the password value.
8. Press and release button DOWN over and over again to set “-19”.
9. Press and release button ENTER again.

To modify a parameter operate as follows:

10. From step 9, press and release button UP or button DOWN to select the parameter (some parameters belong to a possible submenu; press and release button ENTER to gain access to them).
11. Press and release button ENTER.
12. Press and release button UP or button DOWN to modify the value.
13. Press and release button ENTER to confirm the value.
14. Press and release button ESC over and over again to go back to the *Main menu*.

To modify the language of the application software pages operate as follows:

15. From step 2, press and release button UP or button DOWN to select the voice *Language* (according to the factory setting it has value “**English**”).
16. Press and release button ENTER.
17. Press and release button UP or button DOWN to modify the language.
18. Press and release button ENTER to confirm the value.

To modify the real date and time operate as follows:

19. From step 2, press and release button UP or button DOWN to select the voice *Data e ora reale*.
20. Press and release button ENTER.
21. Press and release button UP or button DOWN to modify the value.
22. Press and release button ENTER or button RIGHT to confirm the value and modify the following field (press and release button LEFT or button RIGHT to move among the fields).
23. Repeat steps 21 and 22.

To copy the parameters from the controller to the programming key EVKEY10 operate as follows:

24. Make sure the power supply is switched on.
25. Connect the key to the controller; look at paragraph 8.2.4 "Connection to the controller".
26. Gain access to the submenu *Parameter Key*.
27. Press and release button UP or button DOWN to select "PAR APP" to copy the application software parameters or "PAR DRV" to copy the configuration parameters.
28. Press and release button UP or button DOWN to select "SAVE".
29. Press and release button ENTER: the parameters will be copied from the controller to the key (this operation usually takes a few seconds; if an error had to arise the *LED system alarm* (look at paragraph 5.2.1 "LEDs at the front of the device") will light up and parameter *Key Par* (it belongs to the *Diagnostic* submenu) will assume value *Err*.
30. Disconnect the programming key.

To copy the parameters from the programming key EVKEY10 to the controller operate as follows:

31. Make sure the power supply is switched on.
32. Connect the key to the controller; look at paragraph 8.2.4 "Connection to the controller".
33. Gain access to the submenu *Parameter Key*.
34. Press and release button UP or button DOWN to select "RESTOR".
35. Press and release button ENTER: the parameters will be copied from the key to the controller (this operation usually takes a few seconds; if an error had to arise the *LED system alarm* (look at paragraph 5.2.1 "LEDs at the front of the device") will light up and parameter *Key Par* (it belongs to the *Diagnostic* submenu) will assume value *Err*.
36. Disconnect the programming key.



**The copy of the parameters from the programming key EVKEY10 to the controller is allowed on condition that the firmware of the controllers coincides.**

To quit the procedure operate as follows:

37. Press and release button ESC over and over again; possible modifications will not be saved.



**Switch off the power supply after the modification of the configuration.**



## 6.1.2. Configuring a blind programmable controller

The following procedures show an example of configuration of a blind programmable controller through a built-in programmable controller (in the example it is **c-pro 3 mega**) and through its user interface.



It is also possible to configure the controller using an user interface; look at paragraph 6.3 “Configuring a device through an user interface”.

### Operate as follows:

1. Switch off the power supply of the controllers.
2. Connect the blind controller to the built-in controller through the CAN port; look at chapter 4 “ELECTRICAL CONNECTION”.
3. Switch on the power supply of the controllers.
4. Keep pressed 2 s buttons UP and DOWN: the display will show the following menu.

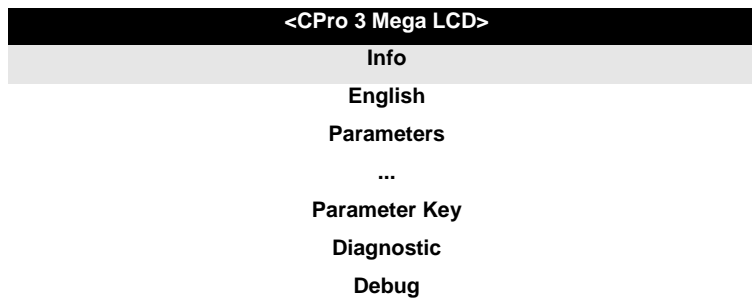

5. Press and release button UP or button DOWN to select “**Networks**”.
6. Press and release button ENTER.
7. Press and release button ENTER again to set the password value.
8. Press and release button DOWN over and over again to set “-19”.
9. Press and release button ENTER again.
10. Press and release button UP or button DOWN to select “**CAN Bus**”.
11. Press and release button ENTER again.
12. Set parameter *NetworkNode* using button UP or button DOWN to select the parameter and using button ENTER to modify and to confirm the value.



According to the factory setting the address of the CAN node of a programmable controller has value 1 (therefore operate on the controller to set parameter *NetworkNode* to [ 1 ] 1).

13. Press and release button UP or button DOWN to select “>”.
14. Press and release button ENTER again: the display will show the *Main menu* of the blind controller.
15. Operate as shown in paragraph 6.1.1 “Configuring a built-in programmable controller”.

## 6.2. Configuring an I / O expansion

The following procedures show an example of configuration of an I / O expansion through a built-in programmable controller (in the example it is **c-pro 3 mega**) and through its user interface.



It is also possible to configure the expansion using an user interface; look at paragraph 6.3 "Configuring a device through an user interface".

Operate as follows:

1. Switch off the power supply of the controller and of the expansion.
2. Connect the controller to the expansion through the CAN port; look at chapter 4 "ELECTRICAL CONNECTION".
3. Switch on the power supply of the controller and of the expansion.
4. Keep pressed 2 s buttons UP and DOWN: the display will show the following menu.

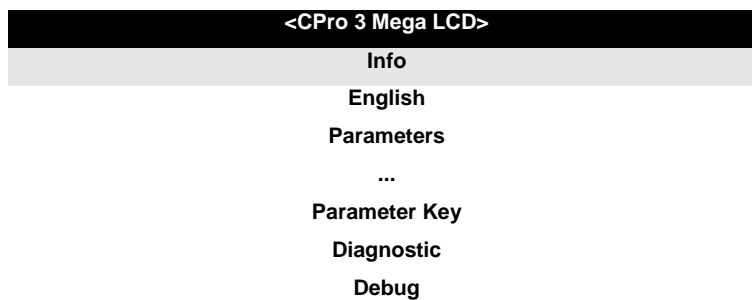

5. Press and release button UP or button DOWN to select "**Networks**".
6. Press and release button ENTER.
7. Press and release button ENTER again to set the password value.
8. Press and release button DOWN over and over again to set "**-19**".
9. Press and release button ENTER again.
10. Press and release button UP or button DOWN to select "**CAN Bus**".
11. Press and release button ENTER again.
12. Set parameter *NetworkNode* using button UP or button DOWN to select the parameter and using button ENTER to modify and to confirm the value.



According to the factory setting the address of the CAN node of an I / O expansion has value 2 (therefore operate on the controller to set parameter *NetworkNode* to [ 2 ] 2).

13. Press and release button UP or button DOWN to select ">".
14. Press and release button ENTER again: the display will show the *Main menu* of the expansion.
15. Operate as shown in paragraph 6.1.1 "Configuring a built-in programmable controller".

## 6.3. Configuring a device through an user interface (*Vgraph*, *Vtouch* or *Vroom*)

The following procedures show an example of configuration of a device through an user interface (in the example *Vgraph*) and through its user interface.

For further information please consult the hardware manual of the user interface.

Operate as follows:

1. Switch off the power supply of the device and of the interface.
2. Connect the device to the interface through the CAN port; look at chapter 4 "ELECTRICAL CONNECTION".
3. Keep pressed 2 s buttons ESC and RIGHT.
4. Switch on the power supply of the device and of the interface.
5. When the display of the interface will show the following menu release buttons ESC and RIGHT.

<b>Vgraph</b>			
<b>Parameters</b>			
<b>Contrast</b>			
<b>CAN Network</b>			
<b>Modbus</b>			
<b>Info</b>			
<b><i>Real date and time</i></b>			

6. Press and release button UP or button DOWN to select "**CAN Network**".
7. Press and release button ENTER.
8. Press and release button ENTER again to set the password value.
9. Press and release button DOWN over and over again to set "-19".
10. Press and release button ENTER again.
11. Set parameter *NW Node* using button UP or button DOWN to select the parameter and using button ENTER to modify and to confirm the value.



According to the factory setting the address of the CAN node of a programmable controller has value 1 (therefore operate on the interface to set parameter *NW Node* to [ 1 ] 1) and the address of the CAN node of an I / O expansion has value 2 (therefore operate on the interface to set parameter *NW Node* to [ 2 ] 2).

12. Switch off the power supply of the interface.
13. Switch on the power supply of the interface.
14. Keep pressed 2 s buttons LEFT and ENTER: the display will show the following menu.

<b>Network Status</b>			
<b>Loc</b>	<b>99</b>	<b>OK</b>	<b>&gt;&gt;</b>
<b>1</b>	<b>1</b>	<b>OK</b>	<b>&gt;&gt;</b>
<b>2</b>	<b>2</b>	<b>OK</b>	<b>&gt;&gt;</b>
<b>3</b>	<b>0</b>	<b>-</b>	<b>&gt;&gt;</b>
<b>4</b>	<b>0</b>	<b>-</b>	<b>&gt;&gt;</b>
<b>5</b>	<b>0</b>	<b>-</b>	<b>&gt;&gt;</b>

15. Press and release button UP or button DOWN to select the device.
16. Press and release button ENTER: the display will show the *Main menu* of the device.
17. Operate as shown in paragraph 6.1.1 "Configuring a built-in programmable controller".

## 6.4. List of configuration parameters

### 6.4.1. List of configuration parameters of *c-pro 3 hecto* and of *c-pro 3 hecto+*

Submenu	Parameter	Min.	Max.	Unit	Preset	Description
Info	PROJ	parameter available in read only modality				information about the application project (project, version and revision)
Info	FW	parameter available in read only modality				information about the firmware (project, version, revision and subrevision)
Info	HW	parameter available in read only modality				information about the hardware (version, revision, generic (G) or special (S))
Info	SW	parameter available in read only modality				information about UNI-PRO 3 (version and revision)
Info	SN	parameter available in read only modality				information about the serial number and the result of the productive test
Info	MASK	parameter available in read only modality				information about the mask (it depends on the builder's coding system)
Info	date and time	parameter available in read only modality				date and time of the last compilation of the application project
Parameters (1)	AI1	---	---	---	NTC	kind of probe analog input 1 PTC = PTC probe NTC = NTC probe 0-20mA = 0-20 mA transducer 4-20mA = 4-20 mA transducer 0-5V = 0-5 V ratiometric transducer 0-10V = 0-10 V ratiometric transducer PT1000 = Pt 1000 probe
Parameters (1)	AI2	---	---	---	NTC	kind of probe analog input 2 PTC = PTC probe NTC = NTC probe 0-20mA = 0-20 mA transducer 4-20mA = 4-20 mA transducer 0-5V = 0-5 V ratiometric transducer 0-10V = 0-10 V ratiometric transducer PT1000 = Pt 1000 probe

Parameters (1)	AI3	---	---	---	NTC	<p>kind of probe analog input 3</p> <p>PTC = PTC probe</p> <p>NTC = NTC probe</p> <p>0-20mA = 0-20 mA transducer</p> <p>4-20mA = 4-20 mA transducer</p> <p>0-5V = 0-5 V ratiometric transducer</p> <p>0-10V = 0-10 V ratiometric transducer</p> <p>PT1000 = Pt 1000 probe</p>
Parameters (1)	AI Err Time	0	240	s	2	analog inputs time-out (after this time without communication with an analog input, the controller signals the analog input error)
Parameters (1)	AO1	---	---	---	PWM	<p>kind of signal analog input 1</p> <p>PWM = PWM (Pulse With Modulation)</p>
Parameters (1)	AO2	---	---	---	0-10V	<p>kind of signal analog input 2</p> <p>0-20mA = 0-20 mA</p> <p>4-20mA = 4-20 mA</p> <p>0-10V = 0-10 V</p>
Parameters (1)	AO3	---	---	---	0-10V	<p>kind of signal analog input 3</p> <p>0-20mA = 0-20 mA</p> <p>4-20mA = 4-20 mA</p> <p>0-10V = 0-10 V</p>
Parameters (1)	CosPhi 10us	---	---	---	---	reserved
Parameters (2) [ press button RIGHT to show it ]	I/O Timeout	1	240	s	60	time-out of the CANbus communication for the test of the remote values of the I / O (after this time without CANbus communication, the I / O of the controller is disabled)
Parameters (2) [ press button RIGHT to show it ]	En. Prg Level	---	---	---	NO	<p>enabling the access to the first level page pressing a combination of buttons</p> <p>YES = yes, operating as follows:</p> <ul style="list-style-type: none"> <li>- keep pressed 3 s button ENTER to gain access to the first page of level 1</li> <li>- keep pressed 3 s buttons ENTER and ESC to gain access to the first page of level 2</li> <li>- keep pressed 3 s buttons LEFT and RIGHT to gain access to the first page of level 3</li> </ul>

Parameters (2) [ press button RIGHT to show it ]	Password Indi	---	---	---	NO	connection among the passwords to gain access to the levels NO = one has not to set any password to gain access to levels lower than the one one has already gained access YES = one has to set a password to gain access to each level
Parameters (2) [ press button RIGHT to show it ]	Debug Baud	----	----	----	19200	baud rate for the debug 19200 = 19,200 baud 28800 = 28,800 baud 38400 = 38,400 baud 57600 = 57,600 baud 76800 = 76,800 baud 115K2 = 115,200 baud
Networks / CAN Bus	MyNode	1	127	---	1	local (or of the controller) CAN node address
Networks / CAN Bus	Master	---	---	---	YES	enabling the operation as master in a CAN network YES = yes
Networks / CAN Bus	Baud	---	---	---	20K	CANbus communication baud rate 20K = 20,000 baud 50K = 50,000 baud 125K = 125,000 baud 500K = 500,000 baud
Networks / CAN Bus	Timeout	1	60	s	5	remote (or with a device in the network) CANbus communication time-out (after this time without CANbus communication with a device, it is excluded by the network)
Networks / CAN Bus	NetworkNode	[ 1 ] 0	[ 32 ] 127	---	[ 1 ] 99	address of a remote (or of a device in the network) CAN node; example for [ 1 ] 2: [ 1 ] = node 2 = node's address
Networks / CAN Bus [ press button RIGHT to show it ]	TSEG1	0	63	---	31	reserved

Networks / CAN Bus [ press button RIGHT to show it ]	TSEG2	1	7	---	7	reserved
Networks / CAN Bus [ press button RIGHT to show it ]	SJW	0	3	---	0	reserved
Networks / CAN Bus [ press button RIGHT to show it ]	BTR(1)	1	15	---	15	reserved
Networks / UART1 (1)	Address	1	247	---	1	local (or of the controller) Modbus node address in a RS-485 network wired on the RS-485 port
Networks / UART1 (1)	Baud Rate	---	---	---	9600	Modbus communication baud rate in a RS-485 network wired on the RS-485 port 1200 = 1,200 baud 2400 = 2,400 baud 4800 = 4,800 baud 9600 = 9,600 baud 19200 = 19,200 baud 28800 = 28,000 baud 38400 = 38,400 baud 57600 = 57,600 baud
Networks / UART1 (1)	Parity	---	---	---	EVEN	Modbus communication parity in a RS-485 network wired on the RS-485 port NONE = no parity ODD = odd EVEN = even
Networks / UART1 (1)	Stop	---	---	---	1 BIT	Modbus communication stop bit number in a RS-485 network wired on the RS-485 port 1 BIT = 1 bit 2 BIT = 2 bit

Networks / UART2 (1)	Timeout	2	240	s	10	Modbus communication time-out in a RS-485 network wired on the RS-485 port for the test of the remote values of the I / O (after this time without Modbus communication, the request is considered not sent and the controller moves to the following request) (1)
Password	Level 1:	-32768	32767	---	0	value of the password to gain access to level 1
		---	---	---	ON	enabling the password to gain access to level 1 OFF = to gain access to level 1 one has not to set any password ON = to gain access to level 1 one has to set a password
Password	Level 2:	-32768	32767	---	0	value of the password to gain access to level 2
		---	---	---	ON	enabling the password to gain access to level 2 OFF = to gain access to level 2 one has not to set any password ON = to gain access to level 2 one has to set a password
Password	Level 3:	-32768	32767	---	0	value of the password to gain access to level 3
		---	---	---	ON	enabling the password to gain access to level 3 OFF = to gain access to level 3 one has not to set any password ON = to gain access to level 3 one has to set a password
Password	Level 4:	-32768	32767	---	0	value of the password to gain access to level 4
		---	---	---	ON	enabling the password to gain access to level 4 OFF = to gain access to level 4 one has not to set any password ON = to gain access to level 4 one has to set a password



Password	Level 5:	-32768	32767	---	0	value of the password to gain access to level 5
		---	---	---	ON	enabling the password to gain access to level 5 OFF = to gain access to level 5 one has not to set any password ON = to gain access to level 5 one has to set a password
Password	Timeout	0	240	s	240	time-out of the passwords to gain access to the levels (after this time since the last operation with the buttons, to gain access to the level one has to set a password again, if foreseen)
Diagnostic	FRAM	parameter available in read only modality				non volatile memory status ok = not in error err = in error
Diagnostic	RTC	parameter available in read only modality				clock status ok = not in error err = in error low = loss of data
Diagnostic	STACK	parameter available in read only modality				stack status ok = not in error err = in error (because of overflow)
Diagnostic	Power Supply	parameter available in read only modality				power supply voltage status ok = not in error err = in error (because of out of range voltage)
Diagnostic	5V Ratio	parameter available in read only modality				status of the power supply voltage of the ratiometric transducers ok = not in error err = in error (because of out of range voltage)
Diagnostic	24V Sensor	parameter available in read only modality				status of the power supply voltage of the 0-20 mA / 4-20 mA / 0-10 V transducers ok = not in error err = in error (because of out of range voltage)

Diagnostic	Math	parameter available in read only modality	<p>Math status</p> <p>ok = not in error</p> <p>err = in error (because of overflow, underflow, division by zero or NaN)</p>
Diagnostic	Key Par	parameter available in read only modality	<p>result of the copy of the parameters from the controller to the programming key EVKEY10 and vice versa</p> <p>ok = operation successful completed</p> <p>err = operazione failed</p>
Debug [ Algo ]	Main time	parameter available in read only modality	main cycle time of the application software (in milliseconds)
	Int. time	parameter available in read only modality	interrupt cycle time of the application software (in milliseconds)
Debug [ CAN bus ]	rx	parameter available in read only modality	number of packages in transmission
	tx	parameter available in read only modality	number of packages in reception
Debug [ CAN bus ]	err	parameter available in read only modality	number of packages in error
	ovf	parameter available in read only modality	number of packages in overflow
Debug	5VP	parameter available in read only modality	reading the power supply voltage of the ratiometric transducers
Debug	24VP	parameter available in read only modality	reading the power supply voltage of the 0-20 mA / 4-20 mA / 0-10 V transducers
Debug	Stack	parameter available in read only modality	minimum free stack
	Buf	parameter available in read only modality	number of free buffers

**Notes:**

- (1) the submenu is visible on condition that the application software expects the RS-485 port is configured to support the Modbus communication protocol.

### 6.4.2. List of configuration parameters of *c-pro 3 mega* and of *c-pro 3 NODE mega*

Submenu	Parameter	Min.	Max.	Unit	Preset	Description
Info	PROJ	parameter available in read only modality				information about the application project (project, version and revision)
Info	FW	parameter available in read only modality				information about the firmware (project, version, revision and subrevision)
Info	HW	parameter available in read only modality				information about the hardware (version, revision, generic (G) or special (S))
Info	SW	parameter available in read only modality				information about UNI-PRO 3 (version and revision)
Info	SN	parameter available in read only modality				information about the serial number and the result of the productive test
Info	MASK	parameter available in read only modality				information about the mask (it depends on the builder's coding system)
Info	date and time	parameter available in read only modality				date and time of the last compilation of the application project
Parameters (1)	AI1	---	---	---	NTC	kind of probe analog input 1 PTC = PTC probe NTC = NTC probe 0-20mA = 0-20 mA transducer 4-20mA = 4-20 mA transducer 0-5V = 0-5 V ratiometric transducer 0-10V = 0-10 V ratiometric transducer PT1000 = Pt 1000 probe
Parameters (1)	AI2	---	---	---	NTC	kind of probe analog input 2 PTC = PTC probe NTC = NTC probe 0-20mA = 0-20 mA transducer 4-20mA = 4-20 mA transducer 0-5V = 0-5 V ratiometric transducer 0-10V = 0-10 V ratiometric transducer PT1000 = Pt 1000 probe

Parameters (1)	AI3	---	---	---	NTC	kind of probe analog input 3 PTC = PTC probe NTC = NTC probe 0-20mA = 0-20 mA transducer 4-20mA = 4-20 mA transducer 0-5V = 0-5 V ratiometric transducer 0-10V = 0-10 V ratiometric transducer PT1000 = Pt 1000 probe
Parameters (1)	AI4	---	---	---	NTC	kind of probe analog input 4 PTC = PTC probe NTC = NTC probe 0-20mA = 0-20 mA transducer 4-20mA = 4-20 mA transducer 0-5V = 0-5 V ratiometric transducer 0-10V = 0-10 V ratiometric transducer PT1000 = Pt 1000 probe
Parameters (1)	AI5	---	---	---	NTC	kind of probe analog input 5 PTC = PTC probe NTC = NTC probe 0-20mA = 0-20 mA transducer 4-20mA = 4-20 mA transducer 0-5V = 0-5 V ratiometric transducer 0-10V = 0-10 V ratiometric transducer PT1000 = Pt 1000 probe
Parameters (1)	AI Err Time	0	240	s	2	analog inputs time-out (after this time without communication with an analog input, the controller signals the analog input error)
Parameters (1)	AO1	---	---	---	PWM	kind of signal analog input 1 PWM = PWM (Pulse With Modulation)
Parameters (1)	AO2	---	---	---	0-10V	kind of signal analog input 2 0-20mA = 0-20 mA 4-20mA = 4-20 mA 0-10V = 0-10 V
Parameters (1)	AO3	---	---	---	0-10V	kind of signal analog input 3 0-20mA = 0-20 mA 4-20mA = 4-20 mA 0-10V = 0-10 V
Parameters (1)	CosPhi 10us	---	---	---	---	reserved

<p>Parameters (2) [ press button RIGHT to show it ]</p>	<p>I/O Timeout</p>	<p>1</p>	<p>240</p>	<p>s</p>	<p>60</p>	<p>time-out of the CANbus communication for the test of the remote values of the I / O (after this time without CANbus communication, the I / O of the controller is disabled)</p>
<p>Parameters (2) [ press button RIGHT to show it ]</p>	<p>En. Prg Level</p>	<p>---</p>	<p>---</p>	<p>---</p>	<p>NO</p>	<p>enabling the access to the first level page pressing a combination of buttons                  YES = yes, operating as follows:                  - keep pressed 3 s button ENTER to gain access to the first page of level 1                  - keep pressed 3 s buttons ENTER and ESC to gain access to the first page of level 2                  - keep pressed 3 s buttons LEFT and RIGHT to gain access to the first page of level 3</p>
<p>Parameters (2) [ press button RIGHT to show it ]</p>	<p>Password Indi</p>	<p>---</p>	<p>---</p>	<p>---</p>	<p>NO</p>	<p>connection among the passwords to gain access to the levels                  NO = one has not to set any password to gain access to levels lower than the one one has already gained access                  YES = one has to set a password to gain access to each level</p>
<p>Parameters (2) [ press button RIGHT to show it; not available in the blind versions ]</p>	<p>Backlight</p>	<p>---</p>	<p>---</p>	<p>---</p>	<p>TIME</p>	<p>kind of backlight                  OFF = the backlight is never lit                  ON = the backlight is always lit                  TIME = the backlight is lit the time one has set with parameter <i>B. Time</i> since the last operation with the buttons</p>
<p>Parameters (2) [ press button RIGHT to show it; not available in the blind versions ]</p>	<p>B. Time</p>	<p>0</p>	<p>60</p>	<p>s</p>	<p>240</p>	<p>backlight duration (only if parameter <i>Backlight</i> has value <i>TIME</i>)</p>

Parameters (2) [ press button RIGHT to show it; not available in the blind versions ]	Contrast	0	100	---	50	display contrast
Parameters (2) [ press button RIGHT to show it; not available in the blind versions ]	Date Char Sep	---	---	---	/	date separator (ASCII character)
Parameters (2) [ press button RIGHT to show it; not available in the blind versions ]	Year format	---	---	---	YY	year format YY = two numbers (for example 10) YYYY = four numbers (for example 2010)
Parameters (2) [ press button RIGHT to show it; not available in the blind versions ]	Date format	---	---	---	D-M-Y	date format D-M-Y = day, month and year M-D-Y = month, day and year Y-M-D = year, month and day
Parameters (2) [ press button RIGHT to show it; not available in the blind versions ]	Time Char Sep	---	---	---	:	time separator (ASCII character)
Parameters (2) [ press button RIGHT to show it; not available in the blind versions ]	Time With Sec	---	---	---	YES	showing the seconds in the real time YES = yes
Parameters (2) [ press button RIGHT to show it; not available in the blind versions ]	Time AM/PM	---	---	---	NO	time format NO = 24 h (for example 15:20) YES = 12 h (for example 3:20 PM)

Parameters (2) [ press button RIGHT to show it ]	Debug Baud	----	----	----	19200	baud rate for the debug 19200 = 19,200 baud 28800 = 28,800 baud 38400 = 38,400 baud 57600 = 57,600 baud 76800 = 76,800 baud 115K2 = 115,200 baud
Networks / CAN Bus	MyNode	1	127	---	1	local (or of the controller) CAN node address
Networks / CAN Bus	Master	---	---	---	YES	enabling the operation as master in a CAN network YES = yes
Networks / CAN Bus	Baud	---	---	---	20K	CANbus communication baud rate 20K = 20,000 baud 50K = 50,000 baud 125K = 125,000 baud 500K = 500,000 baud
Networks / CAN Bus	Timeout	1	60	s	5	remote (or with a device in the network) CANbus communication time-out (after this time without CANbus communication with a device, it is excluded by the network)
Networks / CAN Bus	NetworkNode	[ 1 ] 0	[ 32 ] 127	---	[ 1 ] 99	address of a remote (or of a device in the network) CAN node; example for [ 1 ] 2: [ 1 ] = node 2 = node's address
Networks / CAN Bus [ press button RIGHT to show it ]	TSEG1	0	63	---	31	reserved
Networks / CAN Bus [ press button RIGHT to show it ]	TSEG2	1	7	---	7	reserved
Networks / CAN Bus [ press button RIGHT to show it ]	SJW	0	3	---	0	reserved

Networks / CAN Bus [ press button RIGHT to show it ]	BTR(1)	1	15	---	15	reserved
Networks / BMS (4)	MAC ID	-1	127	---	-1	local (or of the controller) BACnet MS/TP node address -1 = not enabled
Networks / BMS (4)	Baud Rate	---	---	---	19200	BACnet MS/TP communication baud rate 9600 = 9,600 baud 19200 = 19,200 baud 38400 = 28,000 baud 76800 = 76,800 baud
Networks / BMS (4)	Max Master	0	127	---	127	maximum number of master in a BACnet MS/TP network
Networks / BMS (4)	Max InfoFram	1	127	---	3	maximum number of packages transmitted as master before giving the token
Networks / BMS (4)	Device ID	1	4194303	---	108	identity in a BACnet MS/TP multinetwork
Networks / UART1 (1)	Address	1	247	---	1	local (or of the controller) Modbus node address in a RS-485 network wired on the first RS-485 port
Networks / UART1 (1)	Baud Rate	---	---	---	9600	Modbus communication baud rate in a RS-485 network wired on the first RS-485 port 1200 = 1,200 baud 2400 = 2,400 baud 4800 = 4,800 baud 9600 = 9,600 baud 19200 = 19,200 baud 28800 = 28,000 baud 38400 = 38,400 baud 57600 = 57,600 baud
Networks / UART1 (1)	Parity	---	---	---	EVEN	Modbus communication parity in a RS-485 network wired on the first RS-485 port NONE = no parity ODD = odd EVEN = even



Networks / UART1 (1)	Stop	---	---	---	1 BIT	Modbus communication stop bit number in a RS-485 network wired on the first RS-485 port 1 BIT = 1 bit 2 BIT = 2 bit
Networks / UART2 (2)	Address	1	247	---	1	local (or of the controller) Modbus node address in a RS-485 network wired on the second RS-485 port
Networks / UART2 (2)	Baud Rate	---	---	---	9600	Modbus communication baud rate in a RS-485 network wired on the second RS-485 port 1200 = 1,200 baud 2400 = 2,400 baud 4800 = 4,800 baud 9600 = 9,600 baud 19200 = 19,200 baud 28800 = 28,000 baud 38400 = 38,400 baud 57600 = 57,600 baud
Networks / UART2 (2)	Parity	---	---	---	EVEN	Modbus communication parity in a RS-485 network wired on the second RS-485 port NONE = no parity ODD = odd EVEN = even
Networks / UART2 (2)	Stop	---	---	---	1 BIT	Modbus communication stop bit number in a RS-485 network wired on the second RS-485 port 1 BIT = 1 bit 2 BIT = 2 bit
Networks / UART2 (2)	Timeout	2	240	s	10	Modbus communication time-out in a RS-485 network wired on the second RS-485 port for the test of the remote values of the I / O (after this time without Modbus communication, the request is considered not sent and the controller moves to the following request) (3)
Password	Level 1:	-32768	32767	---	0	value of the password to gain access to level 1

		---	---	---	ON	<p>enabling the password to gain access to level 1</p> <p>OFF = to gain access to level 1 one has not to set any password</p> <p>ON = to gain access to level 1 one has to set a password</p>
Password	Level 2:	-32768	32767	---	0	value of the password to gain access to level 2
		---	---	---	ON	<p>enabling the password to gain access to level 2</p> <p>OFF = to gain access to level 2 one has not to set any password</p> <p>ON = to gain access to level 2 one has to set a password</p>
Password	Level 3:	-32768	32767	---	0	value of the password to gain access to level 3
		---	---	---	ON	<p>enabling the password to gain access to level 3</p> <p>OFF = to gain access to level 3 one has not to set any password</p> <p>ON = to gain access to level 3 one has to set a password</p>
Password	Level 4:	-32768	32767	---	0	value of the password to gain access to level 4
		---	---	---	ON	<p>enabling the password to gain access to level 4</p> <p>OFF = to gain access to level 4 one has not to set any password</p> <p>ON = to gain access to level 4 one has to set a password</p>
Password	Level 5:	-32768	32767	---	0	value of the password to gain access to level 5
		---	---	---	ON	<p>enabling the password to gain access to level 5</p> <p>OFF = to gain access to level 5 one has not to set any password</p> <p>ON = to gain access to level 5 one has to set a password</p>

Password	Timeout	0	240	s	240	time-out of the passwords to gain access to the levels (after this time since the last operation with the buttons, to gain access to the level one has to set a password again, if foreseen)
Diagnostic	FRAM	parameter available in read only modality				time-out of the passwords to gain access to the levels (after this time since the last operation with the buttons, to gain access to the level one has to set a password again, if foreseen)
Diagnostic	RTC	parameter available in read only modality				non volatile memory status ok = not in error err = in error
Diagnostic	STACK	parameter available in read only modality				clock status ok = not in error err = in error low = loss of data
Diagnostic	Power Supply	parameter available in read only modality				stack status ok = not in error err = in error (because of overflow)
Diagnostic	5V Ratio	parameter available in read only modality				power supply voltage status ok = not in error err = in error (because of out of range voltage)
Diagnostic	24V Sensor	parameter available in read only modality				status of the power supply voltage of the ratiometric transducers ok = not in error err = in error (because of out of range voltage)
Diagnostic	24V CAN bus	parameter available in read only modality				status of the power supply voltage of the user interface ok = not in error err = in error (because of out of range voltage)
Diagnostic	Math	parameter available in read only modality				Math status ok = not in error err = in error (because of overflow, underflow, division by zero or NaN)

Diagnostic	Key Par	parameter available in read only modality	result of the copy of the parameters from the controller to the programming key EVKEY10 and vice versa ok = operation successful completed err = operazione failed
Debug [ Algo ]	Main time	parameter available in read only modality	main cycle time of the application software (in milliseconds)
	Int. time	parameter available in read only modality	interrupt cycle time of the application software (in milliseconds)
Debug [ CAN bus ]	rx	parameter available in read only modality	number of packages in transmission
	tx	parameter available in read only modality	number of packages in reception
Debug [ CAN bus ]	err	parameter available in read only modality	number of packages in error
	ovf	parameter available in read only modality	number of packages in overflow
Debug	24VPS	parameter available in read only modality	misura della tensione di alimentazione
	5VP	parameter available in read only modality	reading the power supply voltage of the ratiometric transducers
Debug	24VP	parameter available in read only modality	reading the power supply voltage of the 0-20 mA / 4-20 mA / 0-10 V transducers
	24VE	parameter available in read only modality	reading the power supply voltage of the user interface
Debug	Stack	parameter available in read only modality	minimum free stack
	Buf	parameter available in read only modality	number of free buffers

**Notes:**

- (1) the submenu is visible on condition that the application software expects the first RS-485 port is configured to support the Modbus communication protocol
- (2) the submenu is visible on condition that the application software expects the second RS-485 port is configured to support the Modbus communication protocol
- (3) the parameter is meaningful on condition that the second RS-485 port is configured to support the Modbus master communication protocol
- (4) the parameter is visible only in **c-pro 3 NODE mega**.

### 6.4.3. List of configuration parameters of *c-pro 3 mega+*

Submenu	Parameter	Min.	Max.	Unit	Preset	Description
Info	PROJ	parameter available in read only modality				information about the application project (project, version and revision)
Info	FW	parameter available in read only modality				information about the firmware (project, version, revision and subrevision)
Info	HW	parameter available in read only modality				information about the hardware (version, revision, generic (G) or special (S))
Info	SW	parameter available in read only modality				information about UNI-PRO 3 (version and revision)
Info	SN	parameter available in read only modality				information about the serial number and the result of the productive test
Info	MASK	parameter available in read only modality				information about the mask (it depends on the builder's coding system)
Info	date and time	parameter available in read only modality				date and time of the last compilation of the application project
Parameters (1)	AI1	---	---	---	NTC	kind of probe analog input 1 PTC = PTC probe NTC = NTC probe 0-20mA = 0-20 mA transducer 4-20mA = 4-20 mA transducer 0-5V = 0-5 V ratiometric transducer 0-10V = 0-10 V ratiometric transducer PT1000 = Pt 1000 probe NTC2 = NTC 2 probe NTC3 = NTC 3 probe
Parameters (1)	AI2	---	---	---	NTC	kind of probe analog input 2 PTC = PTC probe NTC = NTC probe 0-20mA = 0-20 mA transducer (6) 4-20mA = 4-20 mA transducer (6) 0-5V = 0-5 V ratiometric transducer (6) 0-10V = 0-10 V ratiometric transducer (6) PT1000 = Pt 1000 probe NTC2 = NTC 2 probe NTC3 = NTC 3 probe

Parameters (1)	AI3	---	---	---	NTC	kind of probe analog input 3 PTC = PTC probe NTC = NTC probe 0-20mA = 0-20 mA transducer 4-20mA = 4-20 mA transducer 0-5V = 0-5 V ratiometric transducer 0-10V = 0-10 V ratiometric transducer PT1000 = Pt 1000 probe NTC2 = NTC 2 probe NTC3 = NTC 3 probe
Parameters (1)	AI4	---	---	---	NTC	kind of probe analog input 4 PTC = PTC probe NTC = NTC probe 0-20mA = 0-20 mA transducer 4-20mA = 4-20 mA transducer 0-5V = 0-5 V ratiometric transducer 0-10V = 0-10 V ratiometric transducer PT1000 = Pt 1000 probe NTC2 = NTC 2 probe NTC3 = NTC 3 probe
Parameters (1)	AI5	---	---	---	NTC	kind of probe analog input 5 PTC = PTC probe NTC = NTC probe 0-20mA = 0-20 mA transducer 4-20mA = 4-20 mA transducer 0-5V = 0-5 V ratiometric transducer 0-10V = 0-10 V ratiometric transducer PT1000 = Pt 1000 probe NTC2 = NTC 2 probe NTC3 = NTC 3 probe
Parameters (1)	AI6	---	---	---	NTC	kind of probe analog input 6 NTC = NTC probe 0-20mA = 0-20 mA transducer 4-20mA = 4-20 mA transducer
Parameters (1)	AI7	---	---	---	NTC	kind of probe analog input 7 NTC = NTC probe 0-20mA = 0-20 mA transducer 4-20mA = 4-20 mA transducer
Parameters (1)	AI8	---	---	---	NTC	kind of probe analog input 8 NTC = NTC probe 0-20mA = 0-20 mA transducer 4-20mA = 4-20 mA transducer

Parameters (1)	AI Err Time	0	240	s	2	analog inputs time-out (after this time without communication with an analog input, the controller signals the analog input error)
Parameters (1)	AO1	---	---	---	FAN	kind of signal analog input 1 PWM = PWM (Pulse With Modulation) cut phase to drive fans
Parameters (1)	AO2	---	---	---	0-10V	kind of signal analog input 2 0-20mA = 0-20 mA 4-20mA = 4-20 mA 0-10V = 0-10 V
Parameters (1)	AO3	---	---	---	0-10V	kind of signal analog input 3 0-20mA = 0-20 mA 4-20mA = 4-20 mA 0-10V = 0-10 V
Parameters (1)	AO4	---	---	---	0-10V	kind of signal analog input 4 0-10V = 0-10 V PWM = PWM (Pulse With Modulation; 5... 2,000 Hz)
Parameters (1)	AO5	---	---	---	0-10V	kind of signal analog input 5 0-10V = 0-10 V PWM = PWM (Pulse With Modulation; 5... 2,000 Hz)
Parameters (1)	CosPhi 10us	---	---	---	---	reserved
Parameters (2) [ press button RIGHT to show it ]	I/O Timeout	1	240	s	60	time-out of the CANbus communication for the test of the remote values of the I / O (after this time without CANbus communication, the I / O of the controller is disabled)

<p>Parameters (2) [ press button RIGHT to show it ]</p>	<p>En. Prg Level</p>	<p>---</p>	<p>---</p>	<p>---</p>	<p>NO</p>	<p>enabling the access to the first level page pressing a combination of buttons                  YES = yes, operating as follows:                  - keep pressed 3 s button ENTER to gain access to the first page of level 1                  - keep pressed 3 s buttons ENTER and ESC to gain access to the first page of level 2                  - keep pressed 3 s buttons LEFT and RIGHT to gain access to the first page of level 3</p>
<p>Parameters (2) [ press button RIGHT to show it ]</p>	<p>Password Indi</p>	<p>---</p>	<p>---</p>	<p>---</p>	<p>NO</p>	<p>connection among the passwords to gain access to the levels                  NO = one has not to set any password to gain access to levels lower than the one one has already gained access                  YES = one has to set a password to gain access to each level</p>
<p>Parameters (2) [ press button RIGHT to show it; not available in the blind versions ]</p>	<p>Backlight</p>	<p>---</p>	<p>---</p>	<p>---</p>	<p>TIME</p>	<p>kind of backlight                  OFF = the backlight is never lit                  ON = the backlight is always lit                  TIME = the backlight is lit the time one has set with parameter <i>B. Time</i> since the last operation with the buttons</p>
<p>Parameters (2) [ press button RIGHT to show it; not available in the blind versions ]</p>	<p>B. Time</p>	<p>0</p>	<p>60</p>	<p>s</p>	<p>240</p>	<p>backlight duration (only if parameter <i>Backlight</i> has value <i>TIME</i>)</p>
<p>Parameters (2) [ press button RIGHT to show it; not available in the blind versions ]</p>	<p>Contrast</p>	<p>0</p>	<p>100</p>	<p>---</p>	<p>50</p>	<p>display contrast</p>



Parameters (2) [ press button RIGHT to show it; not available in the blind versions ]	Date Char Sep	---	---	---	/	date separator (ASCII character)
Parameters (2) [ press button RIGHT to show it; not available in the blind versions ]	Year format	---	---	---	YY	year format YY = two numbers (for example 10) YYYY = four numbers (for example 2010)
Parameters (2) [ press button RIGHT to show it; not available in the blind versions ]	Date format	---	---	---	D-M-Y	date format D-M-Y = day, month and year M-D-Y = month, day and year Y-M-D = year, month and day
Parameters (2) [ press button RIGHT to show it; not available in the blind versions ]	Time Char Sep	---	---	---	:	time separator (ASCII character)
Parameters (2) [ press button RIGHT to show it; not available in the blind versions ]	Time With Sec	---	---	---	YES	showing the seconds in the real time YES = yes
Parameters (2) [ press button RIGHT to show it; not available in the blind versions ]	Time AM/PM	---	---	---	NO	time format NO = 24 h (for example 15:20) YES = 12 h (for example 3:20 PM)
Parameters (2) [ press button RIGHT to show it ]	Debug Baud	----	----	----	19200	baud rate for the debug 19200 = 19,200 baud 28800 = 28,800 baud 38400 = 38,400 baud 57600 = 57,600 baud 76800 = 76,800 baud 115K2 = 115,200 baud

Networks / CAN Bus	MyNode	1	127	---	1	local (or of the controller) CAN node address
Networks / CAN Bus	Master	---	---	---	YES	enabling the operation as master in a CAN network YES = yes
Networks / CAN Bus	Baud	---	---	---	20K	CANbus communication baud rate 20K = 20,000 baud 50K = 50,000 baud 125K = 125,000 baud 500K = 500,000 baud
Networks / CAN Bus	Timeout	1	60	s	5	remote (or with a device in the network) CANbus communication time-out (after this time without CANbus communication with a device, it is excluded by the network)
Networks / CAN Bus	NetworkNode	[ 1 ] 0	[ 32 ] 127	---	[ 1 ] 99	address of a remote (or of a device in the network) CAN node; example for [ 1 ] 2: [ 1 ] = node 2 = node's address
Networks / CAN Bus [ press button RIGHT to show it ]	TSEG1	0	63	---	31	reserved
Networks / CAN Bus [ press button RIGHT to show it ]	TSEG2	1	7	---	7	reserved
Networks / CAN Bus [ press button RIGHT to show it ]	SJW	0	3	---	0	reserved
Networks / CAN Bus [ press button RIGHT to show it ]	BTR(1)	1	15	---	15	reserved

Networks / CAN2 Bus (4)	MyNode	1	127	---	1	local (or of the controller) CAN node address
Networks / CAN2 Bus (4)	Master	---	---	---	YES	enabling the operation as master in a CAN network YES = yes
Networks / CAN2 Bus (4)	Baud	---	---	---	20K	CANbus communication baud rate 20K = 20,000 baud 50K = 50,000 baud 125K = 125,000 baud 500K = 500,000 baud
Networks / CAN2 Bus (4)	Timeout	1	60	s	5	remote (or with a device in the network) CANbus communication time-out (after this time without CANbus communication with a device, it is excluded by the network)
Networks / CAN2 Bus (4)	NetworkNode	[ 1 ] 0	[ 32 ] 127	---	[ 1 ] 99	address of a remote (or of a device in the network) CAN node; example for [ 1 ] 2: [ 1 ] = node 2 = node's address
Networks / CAN2 Bus [ press button RIGHT to show it ] (4)	TSEG1	0	63	---	31	reserved
Networks / CAN2 Bus [ press button RIGHT to show it ] (4)	TSEG2	1	7	---	7	reserved
Networks / CAN2 Bus [ press button RIGHT to show it ] (4)	SJW	0	3	---	0	reserved
Networks / CAN2 Bus [ press button RIGHT to show it ] (4)	BTR(1)	1	15	---	15	reserved
Networks / MP Bus (5)	Dev1	0	9953	---	---	serial number of the first Belimo device (first part of the label)

		0	65535	---	---	serial number of the first Belimo device (second part of the label)
		0	255	---	---	serial number of the first Belimo device (fourth part of the label)
Networks / MP Bus (5)	Dev2	0	9953	---	---	serial number of the second Belimo device (first part of the label)
		0	65535	---	---	serial number of the second Belimo device (second part of the label)
		0	255	---	---	serial number of the second Belimo device (fourth part of the label)
Networks / MP Bus (5)	Dev3	0	9953	---	---	serial number of the third Belimo device (first part of the label)
		0	65535	---	---	serial number of the third Belimo device (second part of the label)
		0	255	---	---	serial number of the third Belimo device (fourth part of the label)
Networks / MP Bus (5)	Dev4	0	9953	---	---	serial number of the fourth Belimo device (first part of the label)
		0	65535	---	---	serial number of the fourth Belimo device (second part of the label)
		0	255	---	---	serial number of the fourth Belimo device (fourth part of the label)
Networks / MP Bus (5)	Dev5	0	9953	---	---	serial number of the fifth Belimo device (first part of the label)
		0	65535	---	---	serial number of the fifth Belimo device (second part of the label)
		0	255	---	---	serial number of the fifth Belimo device (fourth part of the label)
Networks / MP Bus (5)	Dev6	0	9953	---	---	serial number of the sixth Belimo device (first part of the label)
		0	65535	---	---	serial number of the sixth Belimo device (second part of the label)

		0	255	---	---	serial number of the sixth Belimo device (fourth part of the label)
Networks / MP Bus (5)	Dev7	0	9953	---	---	serial number of the seventh Belimo device (first part of the label)
		0	65535	---	---	serial number of the seventh Belimo device (second part of the label)
		0	255	---	---	serial number of the seventh Belimo device (fourth part of the label)
Networks / MP Bus (5)	Dev8	0	9953	---	---	serial number of the eighth Belimo device (first part of the label)
		0	65535	---	---	serial number of the eighth Belimo device (second part of the label)
		0	255	---	---	serial number of the eighth Belimo device (fourth part of the label)
Networks / MP Bus Debug [press button RIGHT to show it ] (5)	Dev1	parameter available in read only modality				operation status of the first Belimo device 0 = NotUsed 1 = NotExist 2 = ToConfig 3 = OffLine 4 = InConfig 5 = OnLine
		parameter available in read only modality				errors counter of the first Belimo device
Networks / MP Bus Debug [press button RIGHT to show it ] (5)	Dev2	parameter available in read only modality				operation status of the second Belimo device 0 = NotUsed 1 = NotExist 2 = ToConfig 3 = OffLine 4 = InConfig 5 = OnLine
		parameter available in read only modality				errors counter of the second Belimo device

<p>Networks / MP Bus Debug [press button RIGHT to show it ] (5)</p>	<p>Dev3</p>	<p>parameter available in read only modality</p>	<p>operation status of the third Belimo device 0 = NotUsed 1 = NotExist 2 = ToConfig 3 = OffLine 4 = InConfig 5 = OnLine</p>
		<p>parameter available in read only modality</p>	<p>errors counter of the third Belimo device</p>
<p>Networks / MP Bus Debug [press button RIGHT to show it ] (5)</p>	<p>Dev4</p>	<p>parameter available in read only modality</p>	<p>operation status of the fourth Belimo device 0 = NotUsed 1 = NotExist 2 = ToConfig 3 = OffLine 4 = InConfig 5 = OnLine</p>
		<p>parameter available in read only modality</p>	<p>errors counter of fourth first Belimo device</p>
<p>Networks / MP Bus Debug [press button RIGHT to show it ] (5)</p>	<p>Dev5</p>	<p>parameter available in read only modality</p>	<p>operation status of the fifth Belimo device 0 = NotUsed 1 = NotExist 2 = ToConfig 3 = OffLine 4 = InConfig 5 = OnLine</p>
		<p>parameter available in read only modality</p>	<p>errors counter of the fifth Belimo device</p>
<p>Networks / MP Bus Debug [press button RIGHT to show it ] (5)</p>	<p>Dev6</p>	<p>parameter available in read only modality</p>	<p>operation status of the sixth Belimo device 0 = NotUsed 1 = NotExist 2 = ToConfig 3 = OffLine 4 = InConfig 5 = OnLine</p>
		<p>parameter available in read only modality</p>	<p>errors counter of the sixth Belimo device</p>
<p>Networks / MP Bus Debug [press button RIGHT to show it ] (5)</p>	<p>Dev7</p>	<p>parameter available in read only modality</p>	<p>operation status of the seventh Belimo device 0 = NotUsed 1 = NotExist 2 = ToConfig 3 = OffLine 4 = InConfig 5 = OnLine</p>

		parameter available in read only modality				errors counter of the seventh Belimo device
Networks / MP Bus Debug [press button RIGHT to show it ] (5)	Dev8	parameter available in read only modality				operation status of the eighth Belimo device 0 = NotUsed 1 = NotExist 2 = ToConfig 3 = OffLine 4 = InConfig 5 = OnLine
		parameter available in read only modality				errors counter of the eighth Belimo device
Networks / UART1 (1)	Address	1	247	---	1	local (or of the controller) Modbus node address in a RS-485 network wired on the first RS-485 port
Networks / UART1 (1)	Baud Rate	---	---	---	9600	Modbus communication baud rate in a RS-485 network wired on the first RS-485 port 1200 = 1,200 baud 2400 = 2,400 baud 4800 = 4,800 baud 9600 = 9,600 baud 19200 = 19,200 baud 28800 = 28,000 baud 38400 = 38,400 baud 57600 = 57,600 baud
Networks / UART1 (1)	Parity	---	---	---	EVEN	Modbus communication parity in a RS-485 network wired on the first RS-485 port NONE = no parity ODD = odd EVEN = even
Networks / UART1 (1)	Stop	---	---	---	1 BIT	Modbus communication stop bit number in a RS-485 network wired on the first RS-485 port 1 BIT = 1 bit 2 BIT = 2 bit
Networks / UART2 (2)	Address	1	247	---	1	local (or of the controller) Modbus node address in a RS-485 network wired on the second RS-485 port

Networks / UART2 (2)	Baud Rate	---	---	---	9600	<p>Modbus communication baud rate in a RS-485 network wired on the second RS-485 port</p> <p>1200 = 1,200 baud                  2400 = 2,400 baud                  4800 = 4,800 baud                  9600 = 9,600 baud                  19200 = 19,200 baud                  28800 = 28,000 baud                  38400 = 38,400 baud                  57600 = 57,600 baud</p>
Networks / UART2 (2)	Parity	---	---	---	EVEN	<p>Modbus communication parity in a RS-485 network wired on the second RS-485 port</p> <p>NONE = no parity                  ODD = odd                  EVEN = even</p>
Networks / UART2 (2)	Stop	---	---	---	1 BIT	<p>Modbus communication stop bit number in a RS-485 network wired on the second RS-485 port</p> <p>1 BIT = 1 bit                  2 BIT = 2 bit</p>
Networks / UART2 (2)	Timeout	2	240	s	10	<p>Modbus communication time-out in a RS-485 network wired on the second RS-485 port for the test of the remote values of the I / O (after this time without Modbus communication, the request is considered not sent and the controller moves to the following request) (3)</p>
Password	Level 1:	-32768	32767	---	0	value of the password to gain access to level 1
		---	---	---	ON	<p>enabling the password to gain access to level 1</p> <p>OFF = to gain access to level 1 one has not to set any password                  ON = to gain access to level 1 one has to set a password</p>
Password	Level 2:	-32768	32767	---	0	value of the password to gain access to level 2



		---	---	---	ON	enabling the password to gain access to level 2 OFF = to gain access to level 2 one has not to set any password ON = to gain access to level 2 one has to set a password	
Password	Level 3:	-32768	32767	---	0	value of the password to gain access to level 3	
		---	---	---	ON	enabling the password to gain access to level 3 OFF = to gain access to level 3 one has not to set any password ON = to gain access to level 3 one has to set a password	
Password	Level 4:	-32768	32767	---	0	value of the password to gain access to level 4	
		---	---	---	ON	enabling the password to gain access to level 4 OFF = to gain access to level 4 one has not to set any password ON = to gain access to level 4 one has to set a password	
Password	Level 5:	-32768	32767	---	0	value of the password to gain access to level 5	
		---	---	---	ON	enabling the password to gain access to level 5 OFF = to gain access to level 5 one has not to set any password ON = to gain access to level 5 one has to set a password	
Password	Timeout	0	240	s	240	time-out of the passwords to gain access to the levels (after this time since the last operation with the buttons, to gain access to the level one has to set a password again, if foreseen)	
Diagnostic	FRAM	parameter available in read only modality					time-out of the passwords to gain access to the levels (after this time since the last operation with the buttons, to gain access to the level one has to set a password again, if foreseen)

Diagnostic	RTC	parameter available in read only modality	non volatile memory status ok = not in error err = in error
Diagnostic	STACK	parameter available in read only modality	clock status ok = not in error err = in error low = loss of data
Diagnostic	Power Supply	parameter available in read only modality	stack status ok = not in error err = in error (because of overflow)
Diagnostic	5V Ratio	parameter available in read only modality	power supply voltage status ok = not in error err = in error (because of out of range voltage)
Diagnostic	24V Sensor	parameter available in read only modality	status of the power supply voltage of the ratiometric transducers ok = not in error err = in error (because of out of range voltage)
Diagnostic	24V CAN bus	parameter available in read only modality	status of the power supply voltage of the user interface ok = not in error err = in error (because of out of range voltage)
Diagnostic	Math	parameter available in read only modality	Math status ok = not in error err = in error (because of overflow, underflow, division by zero or NaN)
Diagnostic	Key Par	parameter available in read only modality	result of the copy of the parameters from the controller to the programming key EVKEY10 and vice versa ok = operation successful completed err = operazione failed
Debug [ Algo ]	Main time	parameter available in read only modality	main cycle time of the application software (in milliseconds)
	Int. time	parameter available in read only modality	interrupt cycle time of the application software (in milliseconds)

Debug [ CAN bus ]	rx	parameter available in read only modality	number of packages in transmission
	tx	parameter available in read only modality	number of packages in reception
Debug [ CAN bus ]	err	parameter available in read only modality	number of packages in error
	ovf	parameter available in read only modality	number of packages in overflow
Debug	24VPS	parameter available in read only modality	misura della tensione di alimentazione
	5VP	parameter available in read only modality	reading the power supply voltage of the ratiometric transducers
Debug	24VP	parameter available in read only modality	reading the power supply voltage of the 0-20 mA / 4-20 mA / 0-10 V transducers
	24VE	parameter available in read only modality	reading the power supply voltage of the user interface
Debug	Stack	parameter available in read only modality	minimum free stack
	Buf	parameter available in read only modality	number of free buffers

**Notes:**

- (1) the submenu is visible on condition that the application software expects the first RS-485 port is configured to support the Modbus communication protocol
- (2) the submenu is visible on condition that the application software expects the second RS-485 port is configured to support the Modbus communication protocol
- (3) the parameter is meaningful on condition that the second RS-485 port is configured to support the Modbus master communication protocol
- (4) the parameter is visible only in the models with second CAN port
- (5) the parameter is visible only in the models with MP-Bus port
- (6) not available in the models with second CAN port.

#### 6.4.4. List of configuration parameters of *c-pro 3 EXP hecto* and of *c-pro 3 EXP hecto+*

Submenu	Parameter	Min.	Max.	Unit	Preset	Description
Info	PROJ	parameter available in read only modality				information about the application project (project, version and revision)
Info	FW	parameter available in read only modality				information about the firmware (project, version, revision and subrevision)
Info	HW	parameter available in read only modality				information about the hardware (version, revision, generic (G) or special (S))
Info	SW	parameter available in read only modality				information about UNI-PRO 3 (version and revision)
Info	SN	parameter available in read only modality				information about the serial number and the result of the productive test
Info	MASK	parameter available in read only modality				information about the mask (it depends on the builder's coding system)
Info	date and time	parameter available in read only modality				date and time of the last compilation of the application project
Parameters (1)	AI1	---	---	---	NTC	kind of probe analog input 1 PTC = PTC probe NTC = NTC probe 0-20mA = 0-20 mA transducer 4-20mA = 4-20 mA transducer 0-5V = 0-5 V ratiometric transducer 0-10V = 0-10 V ratiometric transducer PT1000 = Pt 1000 probe
Parameters (1)	AI2	---	---	---	NTC	kind of probe analog input 2 PTC = PTC probe NTC = NTC probe 0-20mA = 0-20 mA transducer 4-20mA = 4-20 mA transducer 0-5V = 0-5 V ratiometric transducer 0-10V = 0-10 V ratiometric transducer PT1000 = Pt 1000 probe

Parameters (1)	AI3	---	---	---	NTC	<p>kind of probe analog input 3</p> <p>PTC = PTC probe</p> <p>NTC = NTC probe</p> <p>0-20mA = 0-20 mA transducer</p> <p>4-20mA = 4-20 mA transducer</p> <p>0-5V = 0-5 V ratiometric transducer</p> <p>0-10V = 0-10 V ratiometric transducer</p> <p>PT1000 = Pt 1000 probe</p>
Parameters (1)	AI Err Time	0	240	s	2	<p>analog inputs time-out (after this time without communication with an analog input, the expansion signals the analog input error)</p>
Parameters (1)	AO1	---	---	---	PWM	<p>kind of signal analog input 1</p> <p>PWM = PWM (Pulse With Modulation)</p>
Parameters (1)	AO2	---	---	---	0-10V	<p>kind of signal analog input 2</p> <p>0-20mA = 0-20 mA</p> <p>4-20mA = 4-20 mA</p> <p>0-10V = 0-10 V</p>
Parameters (1)	AO3	---	---	---	0-10V	<p>kind of signal analog input 3</p> <p>0-20mA = 0-20 mA</p> <p>4-20mA = 4-20 mA</p> <p>0-10V = 0-10 V</p>
Parameters (2) [ press button RIGHT to show it ]	I/O Timeout	1	240	s	60	<p>time-out of the CANbus communication for the test of the remote values of the I / O (after this time without CANbus communication, the I / O of the expansion is disabled)</p>
Networks / CAN Bus	MyNode	1	127	---	2	<p>local (or of the expansion) CAN node address</p>
Networks / CAN Bus	Master	---	---	---	YES	<p>enabling the operation as master in a CAN network</p> <p>YES = yes</p>
Networks / CAN Bus	Baud	---	---	---	20K	<p>CANbus communication baud rate</p> <p>20K = 20,000 baud</p> <p>50K = 50,000 baud</p> <p>125K = 125,000 baud</p> <p>500K = 500,000 baud</p>
Networks / CAN Bus	NetworkNode	[ 1 ] 0	[ 32 ] 127	---	[ 1 ] 99	<p>address of a remote (or of a device in the network) CAN node; example for [ 1 ] 2:</p> <p>[ 1 ] = node</p> <p>2 = node's address</p>

Networks / CAN Bus [ press button RIGHT to show it ]	TSEG1	0	63	---	31	reserved
Networks / CAN Bus [ press button RIGHT to show it ]	TSEG2	1	7	---	7	reserved
Networks / CAN Bus [ press button RIGHT to show it ]	SJW	0	3	---	0	reserved
Networks / CAN Bus [ press button RIGHT to show it ]	BTR(1)	1	15	---	15	reserved
Diagnostic	FRAM	parameter available in read only modality				non volatile memory status ok = not in error err = in error
Diagnostic	5V Ratio	parameter available in read only modality				status of the power supply voltage of the ratiometric transducers ok = not in error err = in error (because of out of range voltage)
Diagnostic	24V Sensor	parameter available in read only modality				status of the power supply voltage of the 0-20 mA / 4-20 mA / 0-10 V transducers ok = not in error err = in error (because of out of range voltage)
Debug [ Algo ]	Main time	parameter available in read only modality				main cycle time of the application software (in milliseconds)
	Int. time	parameter available in read only modality				interrupt cycle time of the application software (in milliseconds)
Debug [ CAN bus ]	rx	parameter available in read only modality				number of packages in transmission
	tx	parameter available in read only modality				number of packages in reception

Debug [ CAN bus ]	err	parameter available in read only modality	number of packages in error
	ovf	parameter available in read only modality	number of packages in overflow
Debug	5VP	parameter available in read only modality	reading the power supply voltage of the ratiometric transducers
Debug	24VP	parameter available in read only modality	reading the power supply voltage of the 0-20 mA / 4-20 mA / 0-10 V transducers
Debug	Stack	parameter available in read only modality	minimum free stack
	Buf	parameter available in read only modality	number of free buffers

## 7. USER INTERFACES

### 7.1. Preliminary information

The controllers in blind version can be used for example with an user interface such as **Vgraph**, **Vtouch** or **Vroom**.

### 7.2. Vgraph

#### 7.2.1. Introduction

**Vgraph** is a new and innovative user interface for the programmable controllers of the family **c-pro 3**.

The main features of the interface are the possibility to communicate to the user a great deal of information and the remarkable ease of control; these features are due to the use of a 128 x 64 pixel single colour LCD graphic display (black with rearlighting through white LEDs), to the 6 buttons (with preset functions) membrane keyboard and to the CAN bus (for the connection to the controllers).

This last also allows the use of the interface in multimaster networks.

Thanks to its constructive features, **Vgraph** offers several mounting typologies; this is possible:

- by panel, at the front of units, of machines for refrigeration or for air conditioning, of electrical panels and as well as in all those applications where a frontal protection degree IP65 is required
- built-in by wall, in traditional box (like "506" by BTicino)
- by wall, on the support CPVW00 by EVCO (to order separately).

Also the necessity to customize the interface, in order to integrate it aesthetically in residential and commercial environments, is satisfied by **Vgraph** since at the front of the interface one can apply both the plates CPVP\* by EVCO (to order separately, made in plastic material and available in two different colorations, white and black) and the numerous plates series "Living" and "Light" by BTicino.

**Vgraph** also has got:

- real time clock
- alarm buzzer.

For further information consult the *Hardware manual of Vgraph*.

#### 7.2.2. Summarizing table of the main features and available models

	<b>Vgraph</b>	
<b>Power supply</b>	24 VAC / 20... 40 VDC not isolated	12... 24 VAC / 15... 40 VDC isolated
<b>Real time clock</b>	incorporated	incorporated
<b>Alarm buzzer</b>	incorporated	incorporated
<b>Display</b>	128 x 64 pixel LCD graphic display	128 x 64 pixel LCD graphic display
<b>Communication ports</b>		
a) CAN port with CANbus communication protocol	2	2
b) programming port	a + b	a + b
<b>Code</b>	EPV4GBR	EPV3GBR

For further models please contact the EVCO's sales network at the address [sales@evco.it](mailto:sales@evco.it).



### 7.2.3. Size

Size in mm (in).

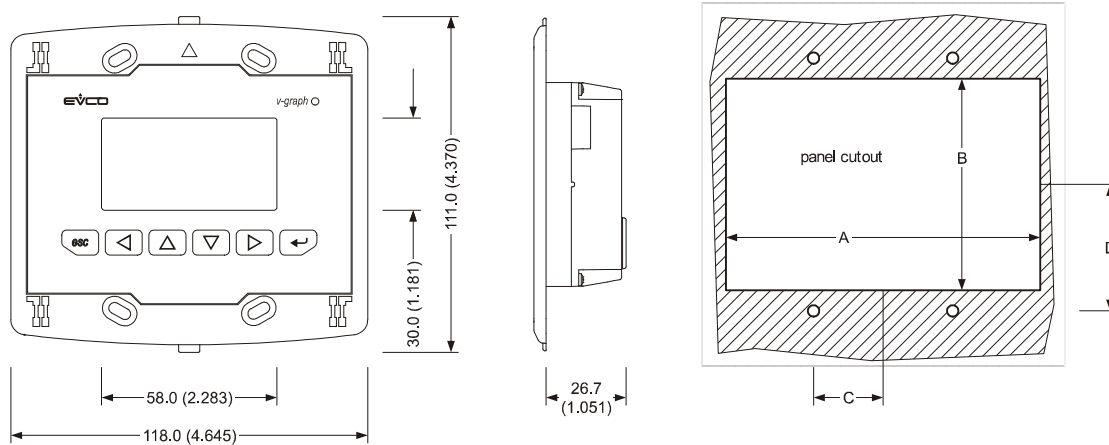

Size	Minimum	Typical	Maximum
A	104.0 (4.094)	104.0 (4.094)	104.8 (4.125)
B	70.0 (2.755)	70.0 (2.755)	70.8 (2.787)
C	22.0 (0.866)	23.0 (0.905)	24.0 (0.944)
D	40.8 (1.606)	41.8 (1.645)	42.8 (1.685)

## 7.3. Vtouch

### 7.3.1. Introduction

**Vtouch** is a new and innovative user interface for the programmable controllers of the family **c-pro 3**.

The main features of the interface are the possibility to communicate to the user a great deal of information and the remarkable ease of control; these features are due to the use of a 240 x 140 pixel single colour touch-screen LCD graphic display (black with rearlighting through white LEDs), to the 6 buttons (with preset functions) membrane keyboard and to the CAN bus (for the connection to the controllers).

This last also allows the use of the interface in multimaster networks.

Thanks to its constructive features, **Vtouch** offers several mounting typologies; this is possible:

- by panel, at the front of units, of machines for refrigeration or for air conditioning, of electrical panels and as well as in all those applications where a frontal protection degree IP65 is required
- built-in by wall, in traditional box (like "506" by BTicino)
- by wall, on the support CPVW00 by EVCO (to order separately).

Also the necessity to customize the interface, in order to integrate it aesthetically in residential and commercial environments, is satisfied by **Vtouch** since at the front of the interface one can apply both the plates CPVP\* by EVCO (to order separately, made in plastic material and available in two different colorations, white and black) and the numerous plates series "Living" and "Light" by BTicino.

**Vtouch** also has got:

- real time clock
- alarm buzzer.

For further information consult the *Hardware manual of Vtouch*.

### 7.3.2. Summarizing table of the main features and available models

	<b>Vtouch</b>	
<b>Power supply</b>	24 VAC / 20... 40 VDC not isolated	12... 24 VAC / 15... 40 VDC isolated
<b>Real time clock</b>	incorporated	incorporated
<b>Alarm buzzer</b>	incorporated	incorporated
<b>Display</b>	240 x 140 pixel touch-screen LCD graphic display	240 x 140 pixel touch-screen LCD graphic display
<b>Communication ports</b>		
a) CAN port with CANbus communication protocol	2	2
b) programming port	a + b	a + b
<b>Code</b>	EPV4TBR	EPV3TBR

For further models please contact the EVCO's sales network at the address [sales@evco.it](mailto:sales@evco.it).

### 7.3.3. Size

Size is in mm (in).

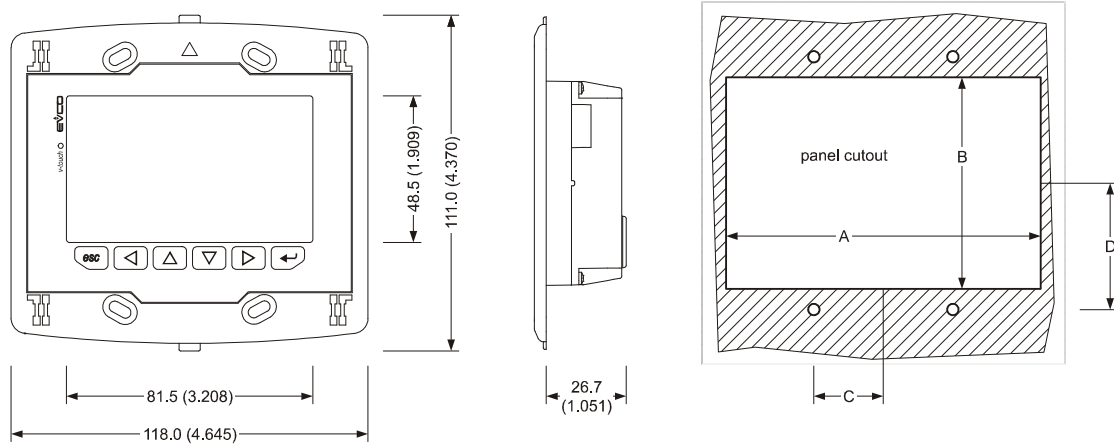

Size	Minimum	Typical	Maximum
A	104.0 (4.094)	104.0 (4.094)	104.8 (4.125)
B	70.0 (2.755)	70.0 (2.755)	70.8 (2.787)
C	22.0 (0.866)	23.0 (0.905)	24.0 (0.944)
D	40.8 (1.606)	41.8 (1.645)	42.8 (1.685)

## 7.4. Vroom

### 7.4.1. Introduction

**Vroom** is a new and innovative user interface for the programmable controllers of the family **c-pro 3**.

The main features of the interface are the possibility to communicate to the user a great deal of information and the remarkable ease of control; these features are due to the use of a 128 x 64 pixel single colour LCD graphic display (black with rearlighting through white LEDs), to the 6 buttons (with preset functions) membrane keyboard and to the CAN bus (for the connection to the controllers).

This last also allows the use of the interface in multimaster networks.

The user interface incorporates a temperature sensor or a temperature and humidity one; the values read by these sensors are transmitted via CAN bus, making easier the wiring.

Thanks to its constructive features, **Vroom** offers several mounting typologies; this is possible:

- by panel, at the front of units, of machines for refrigeration or for air conditioning, of electrical panels and as well as in all those applications where a frontal protection degree IP65 is required
- built-in by wall, in traditional box (like "506" by BTicino)
- by wall, on the support CPVW00 by EVCO (to order separately).

Also the necessity to customize the interface, in order to integrate it aesthetically in residential and commercial environments, is satisfied by **Vroom** since at the front of the interface one can apply both the plates CPVP\* by EVCO (to order separately, made in plastic material and available in two different colorations, white and black) and the numerous plates series "Living" and "Light" by BTicino.

**Vroom** also has got:

- real time clock
- alarm buzzer.

For further information consult the *Hardware manual of Vroom*.

### 7.4.2. Summarizing table of the main features and available models

	<b>Vroom</b>			
<b>Power supply</b>	24 VAC / 20... 40 VDC not isolated	24 VAC / 20... 40 VDC not isolated	12... 24 VAC / 15... 40 VDC isolated	12... 24 VAC / 15... 40 VDC isolated
<b>Real time clock</b>	incorporated	incorporated	incorporated	incorporated
<b>Alarm buzzer</b>	incorporated	incorporated	incorporated	incorporated
<b>Alarm buzzer</b>	temperature	temperature and humidity	temperature	temperature and humidity
<b>Display</b>	128 x 64 pixel LCD graphic display	128 x 64 pixel LCD graphic display	128 x 64 pixel LCD graphic display	128 x 64 pixel LCD graphic display
<b>Communication ports</b>				
a) CAN port with CANbus communication protocol	2 a + b	2 a + b	2 a + b	2 a + b
b) programming port				
<b>Code</b>	EPV4QBR	EPV4RBR	EPV3QBR	EPV3RBR

For further models please contact the EVCO's sales network at the address [sales@evco.it](mailto:sales@evco.it).

### 7.4.3. Size

Size in mm (in).

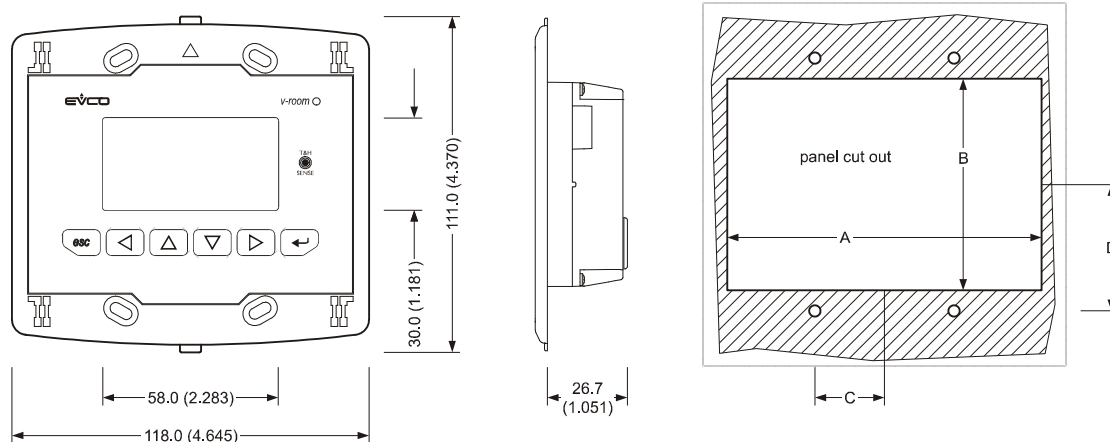

Size	Minimum	Typical	Maximum
A	104.0 (4.094)	104.0 (4.094)	104.8 (4.125)
B	70.0 (2.755)	70.0 (2.755)	70.8 (2.787)
C	22.0 (0.866)	23.0 (0.905)	24.0 (0.944)
D	40.8 (1.606)	41.8 (1.645)	42.8 (1.685)

## 8. ACCESSORIES

### 8.1. Programming kit EVIF20TUXI

#### 8.1.1. Introduction

EVIF20TUXI is a programming kit.

Through the kit it is possible to program the controllers with the application software realized through UNI-PRO 3.

The kit is made of:

- TTL / USB isolated serial interface
- USB cable (to connect the serial interface to the Personal Computer)
- TTL cable (to connect the serial interface to the controller).

#### 8.1.2. Description

The following drawing shows the aspect of the programming kit EVIF20TUXI.

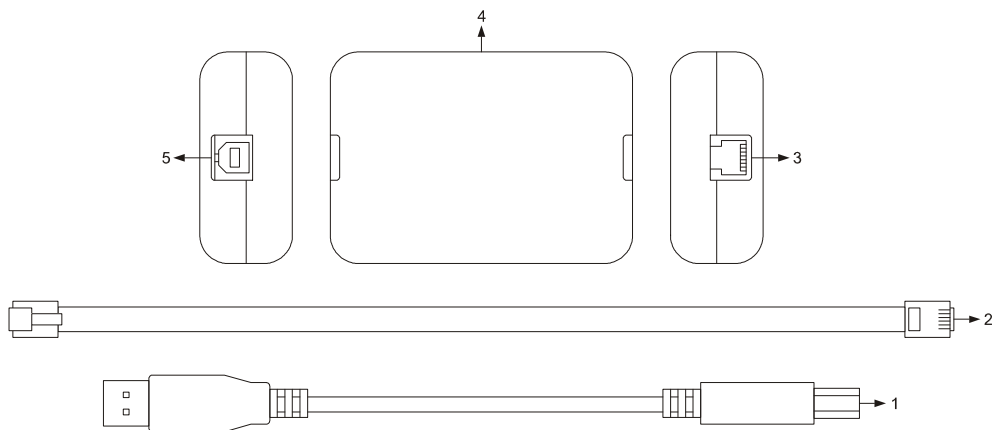

The following table shows the meaning of the parts of the kit.

Part	Meaning
1	USB cable 2 m (6 ft) long
2	TTL cable 2.5 m (8 ft) long
3	TTL port
4	TTL / USB isolated serial interface
5	USB port

### 8.1.3. Size

Size is in mm (in).

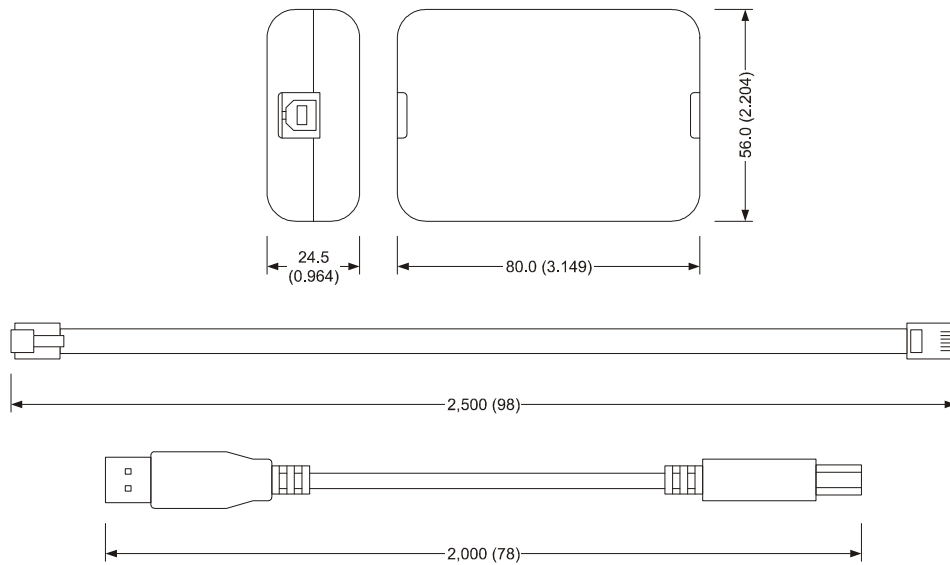

### 8.1.4. Connection to the Personal Computer

Operate as follows:

1. Plug in an end of the TTL cable into the TTL port of the serial interface.
2. Plug in the other end of the TTL cable into the programming and debugging port of the controller.
3. Plug in an end of the USB cable into the USB port of the serial interface.
4. Plug in the other end of the USB cable into an USB port of the Personal Computer.

For further information consult the *Software manual of UNI-PRO 3*.

## 8.2. Programming key EVKEY10

### 8.2.1. Introduction

EVKEY10 is a programming key.

Through the key it is possible to make the upload and the download of the application software parameters and / or of the configuration ones.

The key can be used both with powered controllers and not powered; in this last case one has to use the power supplier EVPS (to order separately).

### 8.2.2. Description

The following drawing shows the aspect of the programming key EVKEY10.

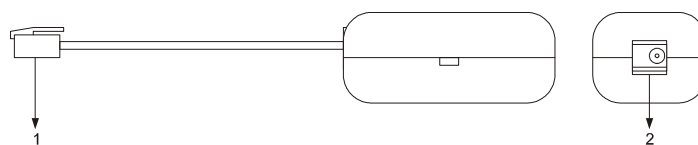

The following table shows the meaning of the parts of the key.

Part	Meaning
1	telephone connector
2	connector for power supplier EVPS

### 8.2.3. Size

Size is in mm (in).

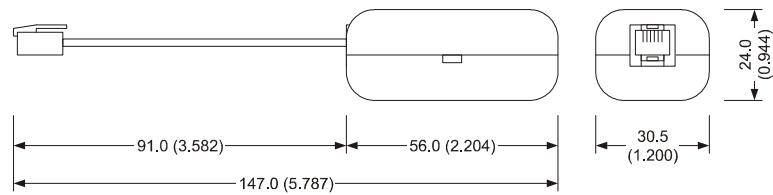

### 8.2.4. Connection to the controller

Operate as follows:

1. Plug in the telephone connector of the key into the programming and debugging port of the controller.

To copy the parameters from the controller to the key and vice-versa look at chapter 6 "CONFIGURATION".

For further information consult the *Software manual of UNI-PRO 3*.



## 9. TECHNICAL DATA

### 9.1. Technical data

<b>Purpose of control:</b>	programmable controller for applications in refrigeration, ventilation and air conditioning.		
<b>Construction of control:</b>	electronic control device to be incorporated.		
<b>Box:</b>	self-extinguishing grey UL94 V0.		
	Heat and fire resistance category: D.		
<b>Size:</b>	<b>c-pro 3 hecto and c-pro 3 hecto+</b>	<b>c-pro 3 mega and c-pro 3 mega+</b>	<b>c-pro 3 EXP hecto and c-pro 3 EXP hecto+</b>
	71.0 x 128.0 x 60.0 mm (2.795 x 5.039 x 2.362 in); 4 DIN modules.	179.0 x 128.0 x 60.0 mm (7.047 x 5.039 x 2.362 in); 10 moduli DIN.	71.0 x 128.0 x 60.0 mm (2.795 x 5.039 x 2.362 in); 4 DIN modules.
		<b>c-pro 3 NODE mega</b>	
		251.0 x 128.0 x 60.0 mm (9.881 x 5.039 x 2.362 in); 14 moduli DIN.	
Size refers to the device with all the connectors properly plugged.			
<b>Installation:</b>	on DIN rail 35.0 x 7.5 mm (1.377 x 0.295 in) or 35.0 x 15.0 mm (1.377 x 0.590 in) according to EN 50022.		
<b>Index of protection:</b>	IP20; IP40 the front.		
<b>Connections:</b>	<b>c-pro 3 hecto and c-pro 3 hecto+</b>	<b>c-pro 3 mega, c-pro 3 mega+ and c-pro 3 NODE mega</b>	<b>c-pro 3 EXP hecto and c-pro 3 EXP hecto+</b>
	male extractable screw terminal blocks pitch 5.0 mm (0.196 in; power supply, inputs, outputs and CAN port) for conductors up to 2.5 mm <sup>2</sup> (0.0038 in <sup>2</sup> ), 8 poles female RJ45 telephone connector (RS-485 port), 6 poles female RJ11 telephone connector (programming and debugging port).	male extractable screw terminal blocks pitch 5.0 mm (0.196 in; power supply, inputs, outputs, CAN and MP-Bus ports) for conductors up to 2.5 mm <sup>2</sup> (0.0038 in <sup>2</sup> ), 8 poles female RJ45 telephone connectors (RS-485 ports), 6 poles female RJ11 telephone connector (programming and debugging port).	male extractable screw terminal blocks pitch 5.0 mm (0.196 in; power supply, inputs, outputs and CAN port) for conductors up to 2.5 mm <sup>2</sup> (0.0038 in <sup>2</sup> ), 6 poles female RJ11 telephone connector (port to update the firmware of the expansion).

	<p>The maximum lengths of the connecting cables are the followings:</p> <ul style="list-style-type: none"> <li>• power supply controller: 30 m (98 ft)</li> <li>• analog inputs: 100 m (328 ft), but AI6, AI7 and AI8 of <b>c-pro 3 mega+</b> (10 m, 32 ft)</li> <li>• power supply transducers: 10 m (32 ft)</li> <li>• digital inputs: 100 m (328 ft), but DI8, DI9, DI10, DI11 and DI12 of <b>c-pro 3 mega+</b> (10 m, 32 ft)</li> <li>• PWM analog output: 1 m (3.280 ft)</li> <li>• 0-20 mA / 4-20 mA / 0-10 V analog outputs: 30 m (98 ft), but AO4 and AO5 of <b>c-pro 3 mega+</b> (10 m, 32 ft)</li> <li>• digital outputs (electromechanical relays): 100 m (328 ft), but DO9 and DO10 of <b>c-pro 3 mega+</b> (10 m, 32 ft)</li> <li>• RS-485 ports: 1,000 m (3,280 ft); also look at the <i>Manuale Modbus specifications and implementation guides</i></li> <li>• MP-Bus port: 10 m (32 ft)</li> <li>• CAN ports:             <ul style="list-style-type: none"> <li>- 1,000 m (3,280 ft) with baud rate 20,000 baud</li> <li>- 500 m (1,640 ft) with baud rate 50,000 baud</li> <li>- 250 m (820 ft) with baud rate 125,000 baud</li> <li>- 50 m (164 ft) with baud rate 500,000 baud</li> </ul> </li> <li>• power supply user interface: 30 m (98 ft).</li> </ul>				
	<table border="1" style="width: 100%; border-collapse: collapse;"> <tr> <td data-bbox="529 920 836 1377" style="width: 50%; vertical-align: top;"> <p>One suggests using the connecting kit CJAV15 (female extractable screw terminal blocks pitch 5.0 mm, 0.196 in; to order separately).</p> </td> <td data-bbox="836 920 1139 1377" style="width: 50%; vertical-align: top;"> <p>For <b>c-pro 3 mega</b> and for <b>c-pro 3 NODE mega</b> one suggests using the connecting kit CJAV16, for <b>c-pro 3 mega+</b> one suggests using the connecting kit CJAV21 (female extractable screw terminal blocks pitch 5.0 mm, 0.196 in; to order separately).</p> </td> </tr> <tr> <td colspan="2" data-bbox="529 1377 1139 1563" style="vertical-align: top;"> <p>To program the controller one has to use the programming kit EVIF20TUXI (TTL / USB isolated serial interface + TTL cable 2.5 m, 8 ft long + USB cable 2 m, 6 ft long; to order separately).</p> </td> </tr> </table>	<p>One suggests using the connecting kit CJAV15 (female extractable screw terminal blocks pitch 5.0 mm, 0.196 in; to order separately).</p>	<p>For <b>c-pro 3 mega</b> and for <b>c-pro 3 NODE mega</b> one suggests using the connecting kit CJAV16, for <b>c-pro 3 mega+</b> one suggests using the connecting kit CJAV21 (female extractable screw terminal blocks pitch 5.0 mm, 0.196 in; to order separately).</p>	<p>To program the controller one has to use the programming kit EVIF20TUXI (TTL / USB isolated serial interface + TTL cable 2.5 m, 8 ft long + USB cable 2 m, 6 ft long; to order separately).</p>	
<p>One suggests using the connecting kit CJAV15 (female extractable screw terminal blocks pitch 5.0 mm, 0.196 in; to order separately).</p>	<p>For <b>c-pro 3 mega</b> and for <b>c-pro 3 NODE mega</b> one suggests using the connecting kit CJAV16, for <b>c-pro 3 mega+</b> one suggests using the connecting kit CJAV21 (female extractable screw terminal blocks pitch 5.0 mm, 0.196 in; to order separately).</p>				
<p>To program the controller one has to use the programming kit EVIF20TUXI (TTL / USB isolated serial interface + TTL cable 2.5 m, 8 ft long + USB cable 2 m, 6 ft long; to order separately).</p>					
<p><b>Working temperature:</b></p>	<p>from -10 to 55 °C (14 to 131 °F) for the built-in versions, from -20 to 55 °C (-4 to 131 °F) for the blind versions.</p>				
<p><b>Storage temperature:</b></p>	<p>from -30 to 70 °C (-22 to 158 °F).</p>				
<p><b>Working humidity:</b></p>	<p>from 5 to 95% of relative humidity without condensate.</p>				
<p><b>Pollution situation:</b></p>	<p>2.</p>				
<p><b>Working altitude:</b></p>	<p>from 0 to 2,000 m (0 to 6591 ft).</p>				
<p><b>Transport altitude:</b></p>	<p>from 0 to 3,048 m (0 to 10,000 ft).</p>				

<b>Ambient conformity:</b>	ROHS 2002 / 95, WEEE 2002 / 96 / EC, REACH CE 1907 / 2006.		
<b>EMC conformity:</b>	EN / IEC 60730-1 enclosure 16.		
<b>Power supply:</b>	<p>24 VAC (<math>\pm 15\%</math>), 50 / 60 Hz (<math>\pm 3</math> Hz), 30 VA max. isolated or 20... 40 VDC, 22 W max. isolated, supplied by a class 2 circuit.</p> <p>The devices incorporate a protection against the reversal of polarity.</p> <p><u>If the controller is powered in direct current, one will not have to respect the polarity of the power supply voltage.</u></p> <p>Protect the power supply of:</p> <ul style="list-style-type: none"> <li>• <b>c-pro 3 hecto</b> and of <b>c-pro 3 EXP hecto</b> with a fuse rated 0.8A-T 250 V</li> <li>• <b>c-pro 3 mega</b> and <b>c-pro 3 mega+</b> with a fuse rated 2.5A-T 250 V.</li> </ul>		
<b>Overvoltage category:</b>	III.		
<b>Consumption:</b>	<b>c-pro 3 hecto</b> and <b>c-pro 3 hecto+</b>	<b>c-pro 3 mega</b> , <b>c-pro 3 mega+</b> and <b>c-pro 3 NODE mega</b>	<b>c-pro 3 EXP hecto</b> and <b>c-pro 3 EXP hecto+</b>
	10 VA max. if the controller is powered in alternate current; 6 W max. if the controller is powered in direct current.	30 VA max. se il controllore viene alimentato in corrente alternata; 22 W max. se il controllore viene alimentato in corrente continua.	10 VA max. if the expansion is powered in alternate current; 6 W max. if the expansion is powered in direct current.
<b>Real time clock:</b>	<b>c-pro 3 hecto</b> and <b>c-pro 3 hecto+</b>	<b>c-pro 3 mega</b> , <b>c-pro 3 mega+</b> and <b>c-pro 3 NODE mega</b>	<b>c-pro 3 EXP hecto</b> and <b>c-pro 3 EXP hecto+</b>
	incorporated (with SuperCap battery).		not available.
	Drift: $\leq$ to 30 s / month at 25 °C (77 °F).		
<b>Alarm buzzer:</b>	<b>c-pro 3 hecto</b> and <b>c-pro 3 hecto+</b>	<b>c-pro 3 mega</b> , <b>c-pro 3 mega+</b> and <b>c-pro 3 NODE mega</b>	<b>c-pro 3 EXP hecto</b> and <b>c-pro 3 EXP hecto+</b>
	not available.	incorporated (not available in the blind versions).	not available.
<b>Analog inputs:</b>	<b>c-pro 3 hecto</b>	<b>c-pro 3 mega</b> and <b>c-pro 3 NODE mega</b>	<b>c-pro 3 EXP hecto</b>

<p>3 non optoisolated inputs, configurable via configuration parameter for PTC / NTC / Pt 1000 probes / 0-20 mA / 4-20 mA / 0-5 V ratiometric / 0-10 V transducers.</p>	<p>5 non optoisolated inputs, configurable via configuration parameter for PTC / NTC / Pt 1000 probes / 0-20 mA / 4-20 mA / 0-5 V ratiometric / 0-10 V transducers.</p>	<p>3 non optoisolated inputs, configurable via configuration parameter for PTC / NTC / Pt 1000 probes / 0-20 mA / 4-20 mA / 0-5 V ratiometric / 0-10 V transducers.</p>
<p><b>c-pro 3 hecto+</b></p>	<p><b>c-pro 3 mega+</b></p>	<p><b>c-pro 3 EXP hecto+</b></p>
<p>4 non optoisolated inputs, of which 3 configurable via configuration parameter for PTC / NTC / Pt 1000 probes / 0-20 mA / 4-20 mA / 0-5 V ratiometric / 0-10 V transducers and 1 for NTC probes.</p>	<p>8 non optoisolated inputs, of which 5 configurable via configuration parameter for PTC / NTC / NTC 2 / NTC 3 / Pt 1000 probes / 0-20 mA / 4-20 mA / 0-5 V ratiometric / 0-10 V transducers and 3 configurable via configuration parameter for NTC / 0-20 mA / 4-20 mA.</p>	<p>4 non optoisolated inputs, of which 3 configurable via configuration parameter for PTC / NTC / Pt 1000 probes / 0-20 mA / 4-20 mA / 0-5 V ratiometric / 0-10 V transducers and 1 for NTC probes</p>
<p>Power supply 0-5 V ratiometric transducers: 5 VDC (+0% -12%), 40 mA max.                  Power supply 0-20 mA / 4-20 mA / 0-10 V transducers: 24 VDC (+50% -25%), 120 mA max.                  The devices incorporate a restorable thermal protection of the power supplies against the short circuit and the overload.</p>		
<p><u>PTC analog inputs (990 Ω @ 25 °C, 77 °F)</u>                  Kind of sensor: KTY 81-121.                  Working range: from -50 to 150 °C (-58 to 302 °F).                  Accuracy: ±0.5% of the full scale between -40 and 100 °C, ±1 °C between -50 and -40 °C and between 100 and 150 °C.                  Resolution: 0.1 °C.                  Conversion time: 100 ms.                  Protection: no protection.</p>		
<p><u>NTC analog inputs (10K Ω @ 25 °C, 77 °F)</u>                  Kind of sensor: β3435.                  Working range: from -50 to 120 °C (-58 to 248 °F).                  Accuracy: ±1 °C.                  Resolution: 0.1 °C.                  Conversion time: 100 ms.                  Protection: no protection.</p>		

	<u>NTC analog inputs (10K Ω @ 25 °C, 77 °F)</u>		
	Kind of sensor: NTC 2.		
	Working range: from -40 to 86 °C (-40 to 186 °F).		
	Accuracy: ±1 °C.		
	Resolution: 0.1 °C.		
Conversion time: 100 ms.			
Protection: no protection.			
<u>NTC analog inputs (10K Ω @ 25 °C, 77 °F)</u>			
Kind of sensor: NTC 2.			
Working range: from -40 to 86 °C (-40 to 186 °F).			
Accuracy: ±0.7% of the full scale between -40 and 100 °C, ±1 °C between -50 to -40 °C and between 100 and 120 °C .			
Resolution: 0.1 °C.			
Conversion time: 100 ms.			
Protection: no protection.			
<u>Pt 1000 analog inputs (1K Ω @ 0 °C, 32 °F)</u>			
Working range: from -100 to 400 °C (-148 to 752 °F ).			
Accuracy: ±0.5% of the full scale.			
Resolution: 0.1 °C.			
Conversion time: 100 ms.			
Protection: no protection.			
<u>0-20 mA / 4-20 mA analog inputs</u>			
Input resistance: ≤ to 200 Ω.			
Accuracy: ±0.5% of the full scale.			
Resolution: 0.01 mA.			
Conversion time: 100 ms.			
Protection: no protection; the maximum current allowed on each input is 25 mA.			
<u>0-5 V ratiometric / 0-10 V analog inputs</u>			
Input resistance: ≥ to 10K Ω.			
Accuracy: ±0.5% of the full scale.			
Resolution: 0.01 V.			
Conversion time: 100 ms.			
Protection: against the reversal of the polarity.			
<b>Digital inputs:</b>	<b>c-pro 3 hecto</b>	<b>c-pro 3 mega</b> and <b>c-pro 3 NODE mega</b>	<b>c-pro 3 EXP hecto</b>
	5 non optoisolated free of voltage digital inputs.	7 optoisolated digital inputs at 24 VAC / DC.	5 non optoisolated free of voltage digital inputs.
	<b>c-pro 3 hecto+</b>	<b>c-pro 3 mega+</b>	<b>c-pro 3 EXP hecto+</b>

	5 optoisolated digital inputs at 24 VAC / DC.	12 optoisolated digital inputs at 24 VAC / DC.	5 optoisolated digital inputs at 24 VAC / DC.
	<p><u>Non optoisolated free of voltage digital inputs</u></p> <p>Power supply: no power supply.</p> <p>Input resistance: <math>\geq</math> to 10K <math>\Omega</math>.</p> <p>Protection: no protection.</p>		
	<p><u>Optoisolated digital inputs at 24 VAC / DC</u></p> <p>Power supply: 24 VAC (<math>\pm</math>15%), 50 / 60 Hz (<math>\pm</math>3 Hz) or 24 VDC (+66% -16%).</p> <p>Input resistance: <math>\geq</math> to 10K <math>\Omega</math>.</p> <p>Protection: no protection.</p>		
<b>Displays:</b>	<b>c-pro 3 hecto</b> and <b>c-pro 3 hecto+</b>	<b>c-pro 3 mega</b> , <b>c-pro 3 mega+</b> and <b>c-pro 3 NODE mega</b>	<b>c-pro 3 EXP hecto</b> and <b>c-pro 3 EXP hecto+</b>
	signalling LEDs.	122 x 32 pixel single colour LCD graphic display (black with rearlighting through white LEDs; not available in the blind versions), signalling LEDs.	signalling LEDs.
<b>Analog outputs:</b>	<b>c-pro 3 hecto</b> and <b>c-pro 3 hecto+</b>	<b>c-pro 3 mega</b> and <b>c-pro 3 NODE mega</b>	<b>c-pro 3 EXP hecto</b> and <b>c-pro 3 EXP hecto+</b>
	<p>3 outputs:</p> <ul style="list-style-type: none"> <li>1 non optoisolated PWM output</li> <li>2 non optoisolated outputs configurable via configuration parameter for 0-20 mA / 4-20 mA / 0-10 V signal.</li> </ul> <p>Power supply driving the PWM analog output: 24 VDC, 50 mA max.</p> <p><u>The PWM analog output is usable on condition that the device is powered in alternate current and the phase powering the device is the same powering the user driven by the output.</u></p>		
	<b>c-pro 3 mega+</b>		
<p>5 outputs:</p> <ul style="list-style-type: none"> <li>1 non optoisolated PWM output (analog output 1)</li> <li>2 non optoisolated outputs configurable via configuration parameter for 0-20 mA / 4-20 mA / 0-10 V signal</li> <li>2 non optoisolated outputs configurable via configuration parameter for PWM / 0-10 V signal.</li> </ul> <p>Power supply driving the PWM analog output 1: 24 VDC, 50 mA max.</p> <p><u>The PWM analog output 1 is usable on condition that the device is powered in alternate current and the phase powering the device is the same powering the user driven by the output.</u></p>			

	<p><u>PWM analog outputs (but the analog outputs 4 and 5 of <b>c-pro 3 mega+</b>)</u></p> <p>Driving power supply: 24 VDC (+16% -25%), 50 mA max.</p> <p>Frequency: the same as the one of the phase powering the device.</p> <p>Protection: no protection.</p>		
	<p><u>0-20 mA / 4-20 mA analog outputs</u></p> <p>Input resistance: 40... 300 Ω.</p> <p>Accuracy: ±3% of the full scale.</p> <p>Resolution: 0.05 mA.</p> <p>Conversion time: 1 s.</p> <p>Protection: restorable thermal protection against the short circuit and the overload.</p>		
	<p><u>0-10 V analog outputs</u></p> <p>Input resistance: 1K Ω min.</p> <p>Accuracy: +2% -5% of the full scale for users having impedance between 1 and 5K Ω, ±2% of the full scale for users having impedance &gt; of 5K Ω.</p> <p>Resolution: 0.01 V.</p> <p>Conversion time: 1 s.</p> <p>Protection: restorable thermal protection against the short circuit and the overload.</p>		
<b>Digital outputs:</b>	<p><b>c-pro 3 hecto</b></p>	<p><b>c-pro 3 mega</b> and <b>c-pro 3 NODE mega</b></p>	<p><b>c-pro 3 EXP hecto</b></p>
	<p>6 outputs (electromechanical relays):</p> <ul style="list-style-type: none"> <li>five 5 res. A @ 250 VAC (6,000 cycles) SPST outputs (K1, K2, K3, K4 and K5)</li> <li>one 8 res. A @ 250 VAC (6,000 cycles) SPDT output (K6).</li> </ul>	<p>8 outputs (electromechanical relays):</p> <ul style="list-style-type: none"> <li>three 5 res. A @ 250 VAC (6,000 cycles) SPST outputs (K1, K5 and K7)</li> <li>four 8 res. A @ 250 VAC (6,000 cycles) SPST outputs (K2, K3, K4 and K6)</li> <li>one 8 res. A @ 250 VAC (6,000 cycles) SPDT output (K8).</li> </ul>	<p>6 outputs (electromechanical relays):</p> <ul style="list-style-type: none"> <li>five 5 res. A @ 250 VAC (6,000 cycles) SPST outputs (K1, K2, K3, K4 and K5)</li> <li>one 8 res. A @ 250 VAC (6,000 cycles) SPDT output (K6).</li> </ul>
	<p><b>c-pro 3 hecto+</b></p>	<p><b>c-pro 3 mega+</b></p>	<p><b>c-pro 3 EXP hecto+</b></p>

	<p>6 outputs (electromechanical relays):</p> <ul style="list-style-type: none"> <li>• five 3 res. A @ 250 VAC (6,000 cycles) SPST outputs (K1, K2, K3, K4 and K5)</li> <li>• one 5 res. A @ 250 VAC (6,000 cycles) SPDT output (K6).</li> </ul>	<p>10 outputs (electromechanical relays):</p> <ul style="list-style-type: none"> <li>• five 5 res. A @ 250 VAC (6,000 cycles) SPST outputs (K1, K5, K7, K9 and K10)</li> <li>• four 8 res. A @ 250 VAC (6,000 cycles) SPST outputs (K2, K3, K4 and K6)</li> <li>• one 8 res. A @ 250 VAC (6,000 cycles) SPDT output (K8).</li> </ul>	<p>6 outputs (electromechanical relays):</p> <ul style="list-style-type: none"> <li>• five 3 res. A @ 250 VAC (6,000 cycles) SPST outputs (K1, K2, K3, K4 and K5)</li> <li>• one 5 res. A @ 250 VAC (6,000 cycles) SPDT output (K6).</li> </ul>
<p>The devices ensure a double isolation among each terminal of the digital outputs and the remaining parts of the device.</p>			
<p><b>Type of actions and additional features:</b></p>	<p>1B.</p>		
<p><b>Communication ports:</b></p>	<p><i>c-pro 3 hecto</i> and <i>c-pro 3 hecto+</i></p>	<p><i>c-pro 3 mega</i>, <i>c-pro 3 mega+</i> and <i>c-pro 3 NODE mega</i></p>	<p><i>c-pro 3 EXP hecto</i> and <i>c-pro 3 EXP hecto+</i></p>



	<p>3 non optoisolated ports:</p> <ul style="list-style-type: none"> <li>• 1 CAN port with CANbus communication protocol</li> <li>• 1 RS-485 port with Modbus master / slave communication protocol (configurable via application software)</li> <li>• 1 programming and debugging port.</li> </ul>	<p>4 non optoisolated ports (5 in <b>c-pro 3 NODE mega</b>):</p> <ul style="list-style-type: none"> <li>• 1 CAN port with CANbus communication protocol</li> <li>• 1 CAN or MP-Bus port (according to the model, only in <b>c-pro 3 mega+</b>)</li> <li>• 1 RS-485 port with Modbus slave communication protocol</li> <li>• 1 RS-485 port with Modbus master / slave communication protocol (configurable via application software)</li> <li>• 1 programming and debugging port</li> <li>• 1 port for gateway <b>c-pro 3 plug-in</b> (only in <b>c-pro 3 NODE mega</b>).</li> </ul> <p>Power supply user interface: 24 VDC, 122 mA max.</p> <p>The controller incorporates a restorable thermal protection of the power supply against the short circuit and the overload.</p>	<p>2 non optoisolated ports:</p> <ul style="list-style-type: none"> <li>• 1 CAN port with CANbus communication protocol</li> <li>• 1 port to update the firmware of the expansion.</li> </ul>
<b>Microprocessor:</b>	16 bit.		
<b>Program memory (FLASH):</b>	<b>c-pro 3 hecto</b> and <b>c-pro 3 hecto+</b>	<b>c-pro 3 mega</b> , <b>c-pro 3 mega+</b> and <b>c-pro 3 NODE mega</b>	<b>c-pro 3 EXP hecto</b> and <b>c-pro 3 EXP hecto+</b>
	288 KB.	544 KB.	-
<b>Data memory (RAM):</b>	<b>c-pro 3 hecto</b> and <b>c-pro 3 hecto+</b>	<b>c-pro 3 mega</b> , <b>c-pro 3 mega+</b> and <b>c-pro 3 NODE mega</b>	<b>c-pro 3 EXP hecto</b> and <b>c-pro 3 EXP hecto+</b>
	12 KB.	24 KB.	-



**c-pro 3**

**PROGRAMMABLE CONTROLLERS**

Hardware manual ver. 3.2

PT - April 2013

Code 114CP3E324

This document belongs to EVCO; unless you are authorized by EVCO, you can not publish it.

EVCO does not take any responsibility about features, technical data and possible mistakes related in this document or coming by its use.

EVCO does not take any responsibility about damages coming by the non-observance of the additional information.

EVCO reserves the right to make any change without prior notice and at any time without prejudice the basic safety and operating features.



**EVCO S.p.A.**

Via Feltre 81, 32036 Sedico Belluno ITALY

Phone +39 / 0437 / 8422

Fax +39 / 0437 / 83.648

[info@evco.it](mailto:info@evco.it)

[www.evco.it](http://www.evco.it)