

# EVK701/EVK702 single output/two outputs digital timers

## ENGLISH GETTING STARTED

**1.1 Important**  
Read these instructions carefully before installing and using the instrument and follow all additional information for installation and electrical connection; keep these instructions close to the instrument for future consultations.

**1.2 Installing the instrument**  
Panel mounting, with click brackets (supplied by the builder); dimensions in mm (in).

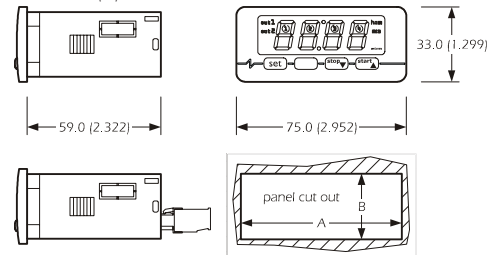

| DIMENS. | MINIMUM      | TYPICAL      | MAXIMUM      |
|---------|--------------|--------------|--------------|
| A       | 71.0 (2.795) | 71.0 (2.795) | 71.8 (2.826) |
| B       | 29.0 (1.141) | 29.0 (1.141) | 29.8 (1.173) |

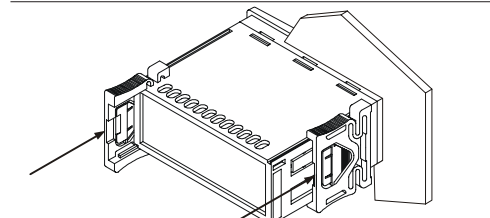

- Additional information for installation:
- 59.0 (2.322) is the maximum depth with screw terminal blocks
  - 83.0 (3.267) is the maximum depth with extractable terminal blocks
  - the panel thickness must not be higher than 8.0 mm (0.314 in)
  - working conditions (working temperature, humidity, etc.) must be between the limits indicated in the technical data
  - do not install the instrument close to heating sources (heaters, hot air ducts, etc.), devices provided with big magnetos (big speakers, etc.), locations subject to direct sunlight, rain, humidity, dust, mechanical vibrations or bumps
  - according to the safety legislation, the protection against electrical parts must be ensured by a correct installation of the instrument; the parts that ensure the protection must be installed so that you can not remove them if not by using a tool.

**1.3 Wiring diagram**  
With reference to the wiring diagrams:

- the serial port (by request) is the port for the communication with the supervision system (through a serial interface, via TTL, with MODBUS communication protocol) or with the programming key; the port must not be used at the same time for the same purposes.

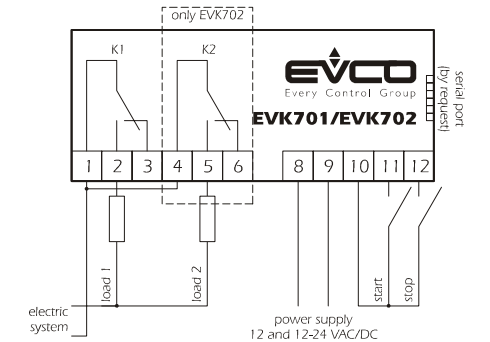
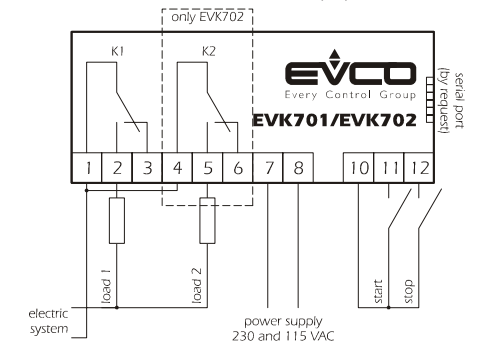

Additional information for electrical connection:

- do not operate on the terminal blocks with electrical or pneumatic screwdrivers

- if the instrument has been moved from a cold location to a warm one, the humidity could condense on the inside; wait about an hour before supplying it
- test the working power supply voltage, working electrical frequency and working electrical power of the instrument; they must correspond with the local power supply
- disconnect the local power supply before servicing the instrument
- do not use the instrument as safety device
- for repairs and information on the instrument please contact Evco sales network.

## 2 USER INTERFACE

**2.1 Turning on/off the instrument**  
To turn on the instrument you have to supply it; to turn it off it is enough to cut off the power supply.  
If a lack of power supply arises when the count is running, the operation of the instrument to the restoration of the power supply will depend on parameter t26.

**2.2 Starting the count**  
• make sure no procedure is running  
• provoke the effect you have set with parameter t11:  
- if t11 = 0, press **start** or activate input start  
- if t11 = 1, press **stop**  
- if t11 = 2, activate input start.

**2.3 Stopping the count**  
• make sure parameter t17 has value 0  
• provoke the effect you have set with parameter t12:  
- if t12 = 0, press **stop** or activate input stop  
- if t12 = 1, press **start**  
- if t12 = 2, activate input stop.

**2.4 Suspending/resuming the count**  
To suspend the count:  
• make sure parameter t17 has value 2  
• provoke the effect you have set with parameter t12:  
- if t12 = 0, press **stop** or activate input stop  
- if t12 = 1, press **start**  
- if t12 = 2, activate input stop.

To resume the count:  
• provoke the effect you have set with parameter t11:  
- if t11 = 0, press **start** or activate input start  
- if t11 = 1, press **stop**  
- if t11 = 2, activate input start.

**2.5 The display**  
If the count is running, the display will show the kind of count you have set with parameter t15:  
• if t15 = 0, the display will show the remaining time (count down)  
• if t15 = 1, the display will show the elapsed time (count up).  
If the count is suspended, the display will flash.

**2.6 Silencing the buzzer in alarm**  
• press a button (the first pressure of the button does not provoke its usual effect).

## 3 OPERATION

**3.1 Preliminary information**  
The operation mainly depends on the instrument code.  
**3.2 Operation with instrument code = 1**

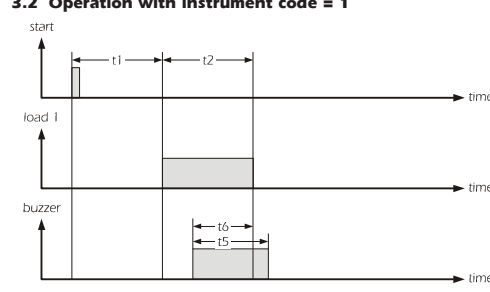

**3.3 Operation with instrument code = 2**

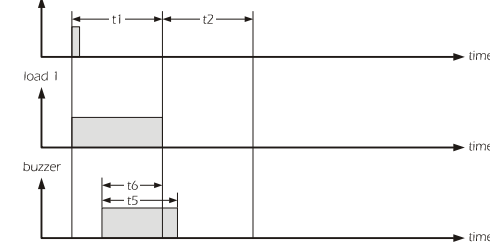

If the cyclical operation is not active (parameter t18 = 0), parameter t2 will not be visible.

**3.4 Operation with instrument code = 3**

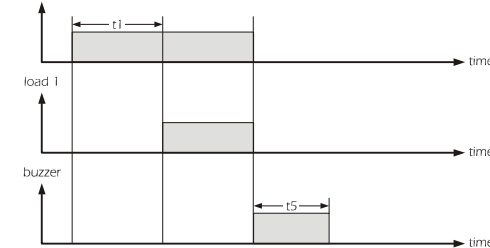

To start the count:  
• make sure parameter t11 has value 0 or 2  
• activate input start.  
To stop the count:  
• press **stop** 4 s.

If the duration of the activation of input start is shorter than the time you have set with parameter t1, load 1 and the buzzer will not be turned on.

**3.5 Operation with instrument code = 4**

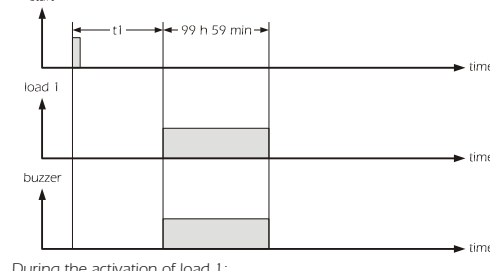

During the activation of load 1:  
• the count is not shown  
• if you try to suspend the count, you will stop it.

**3.6 Operation with instrument code = 5 (only EVK702)**

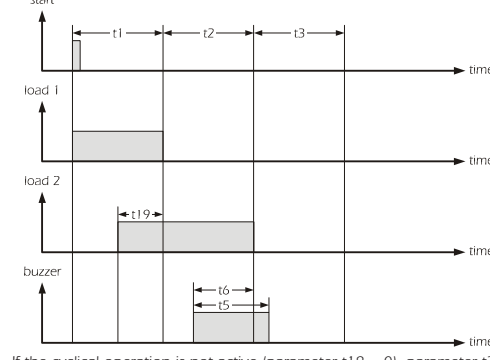

If the cyclical operation is not active (parameter t18 = 0), parameter t3 will not be visible.

**3.7 Operation with instrument code = 6 (only EVK702)**

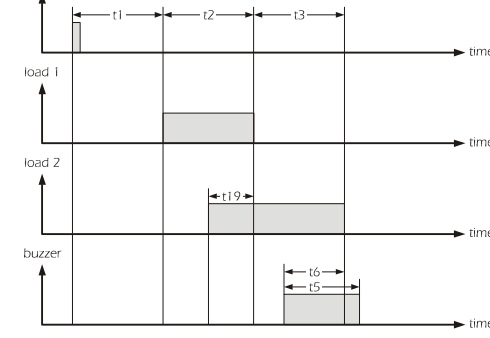

**3.8 Operation with instrument code = 7 (only EVK702)**

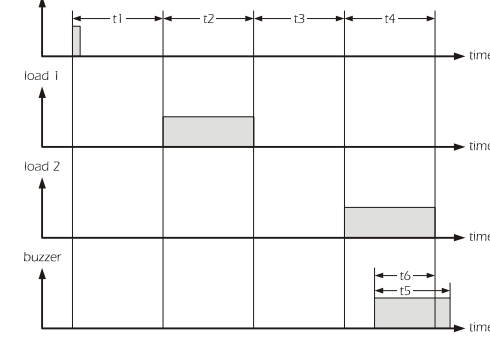

**3.9 Operation with instrument code = 8 (only EVK702)**

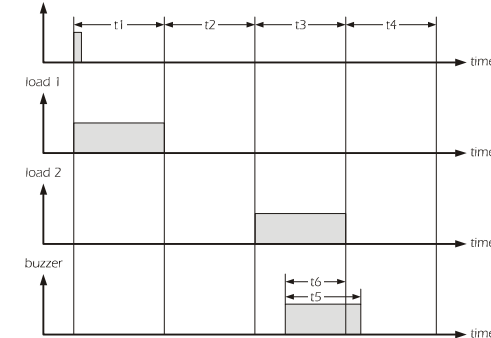

If the cyclical operation is not active (parameter t18 = 0), parameter t4 will not be visible.

**3.10 Operation with instrument code = 9 (only EVK702)**

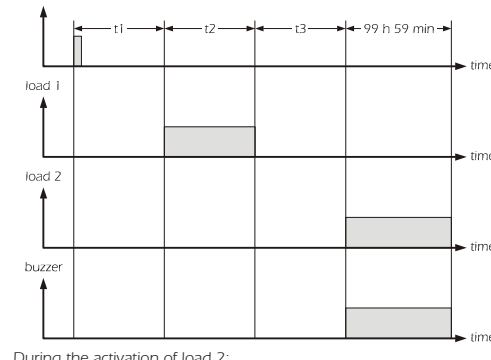

During the activation of load 2:  
• the count is not shown  
• if you try to suspend the count, you will stop it.

## 4 SETTINGS

To gain access the procedure:  
• make sure no count is running and no procedure is running  
• press **start** and **stop** 4 s: the display will show "PA"  
• press **set**  
• press **start** or **stop** in 15 s to set "743"  
• press **set** or do not operate 15 s  
• press **start** and **stop** 4 s: the display will show "DEF"  
• press **set**  
• press **start** or **stop** in 15 s to set "149"  
• press **set** or do not operate 15 s: the display will show "CFG".

To modify the instrument code:  
• press **set**  
• press **start** or **stop** in 15 s  
• press **set** or do not operate 15 s: the display will show "CFG" flashing 4 s, after which the instrument will quit the procedure  
• switch off/on the power supply of the instrument.

To quit the procedure early:  
• press **start** and **stop** 4 s or do not operate 60 s.  
**The modification of the instrument code provokes the restoration of the default value of configuration parameters; to modify the instrument code provoking only the cancellation of the value of parameters t1, t2, t3, t4 and t19, modify parameter CFG with the procedure related in paragraph 4.2.**

**4.2 Setting configuration parameters**  
Configuration parameters are arranged on two levels.  
To gain access the first level:  
• make sure no count is running and no procedure is running  
• press **start** and **stop** 4 s: the display will show "PA"  
To select a parameter:  
• press **start** or **stop**  
To modify a parameter:  
• press **set**  
• press **start** or **stop** in 15 s  
• press **set** or do not operate 15 s.  
To gain access the second level:  
• gain access the first level  
• press **start** or **stop** to select "PA"  
• press **set**  
• press **start** or **stop** in 15 s to set "-19"  
• press **set** or do not operate 15 s  
• press **start** and **stop** 4 s: the display will show "t1".

To quit the procedure:  
• press **start** and **stop** 4 s or do not operate 60 s.  
**Switch off/on the power supply of the instrument after the modification of the parameters.**

**4.3 Setting parameters t1, t2, t3 and t4 quickly**  
To modify parameter t1:  
• make sure no count is running and no procedure is running  
• press **set**: LED **1** will flash

- press **start** or **stop** in 15 s; also look at parameter t20.
- To modify parameter t2 (if provided):  
• press **set** in 15 s: LED **2** will flash
- press **start** or **stop** in 15 s; also look at parameter t21.
- To modify parameter t3 (if provided):  
• press **set** in 15 s: LED **3** will flash
- press **start** or **stop** in 15 s; also look at parameter t22.
- To modify parameter t4 (if provided):  
• press **set** in 15 s: LED **4** will flash
- press **start** or **stop** in 15 s; also look at parameter t23
- press **set** or do not operate 15 s: the instrument will quit the procedure.

To quit the procedure early:  
• do not operate 15 s.

## 5 SIGNALS

| LED          | MEANING  |
|--------------|--|
| <b>out 1</b> | LED load 1<br>if it is lit, load 1 will be turned on   |
| <b>out 2</b> | LED load 2 (only EVK702)<br>if it is lit, load 2 will be turned on   |
| <b>1</b>     | LED time t1<br>if it is lit, the count of the time you have set with parameter t1 will be running<br>if it flashes, the modification of parameter t1 will be running (with the procedure indicated in paragraph 4.3) |
| <b>2</b>     | LED time t2<br>if it is lit, the count of the time you have set with parameter t2 will be running<br>if it flashes, the modification of parameter t2 will be running (with the procedure indicated in paragraph 4.3) |
| <b>3</b>     | LED time t3<br>if it is lit, the count of the time you have set with parameter t3 will be running<br>if it flashes, the modification of parameter t3 will be running (with the procedure indicated in paragraph 4.3) |
| <b>4</b>     | LED time t4<br>if it is lit, the count of the time you have set with parameter t4 will be running<br>if it flashes, the modification of parameter t4 will be running (with the procedure indicated in paragraph 4.3) |
| <b>h:m</b>   | LED hours:minutes<br>if it is lit, the times base of the count that will be running will be hours:minutes  |
| <b>m:s</b>   | LED minutes:seconds<br>if it is lit, the times base of the count that will be running will be minutes:seconds  |

## 6 ALARMS

| CODE                    | MEANING   |
|-------------------------|---|
| <b>display flashing</b> | Lack of power supply during the count<br>Remedies:<br>• check the reasons that have provoked the lack of power supply<br>Effects:<br>• the effect you have set with parameter t26 |

## 7 TECHNICAL DATA

**7.1 Technical data**  
**Box:** self-extinguishing grey.  
**Frontal protection:** IP 65.  
**Connections:** screw terminal blocks (power supply, inputs and outputs), 6 poles connector (serial port; by request); extractable terminal blocks (power supply, inputs and outputs) by request.  
**Working temperature:** from 0 to 55 °C (32 to 131 °F, 10 ... 90% of relative humidity without condensate).  
**Power supply:** 230 VAC, 50/60 Hz, 3 VA (approximate); 115 VAC or 12-24 VAC/DC or 12 VAC/DC by request.  
**Alarm buzzer:** incorporated.  
**Digital inputs:** 2 (start and stop) for NO/NC contact (free of voltage, 5 V 1 mA).

**Working range:** from 1 ds to 99 h and 59 min.  
**Digital outputs EVK701:** 1 relay:  
• **load 1 relay:** 8 res. A @ 250 VAC (change-over contact).  
**Digital outputs EVK702:** 2 relays:  
• **load 1 relay:** 8 res. A @ 250 VAC (change-over contact).  
• **load 2 relay:** 8 res. A @ 250 VAC (change-over contact).

**Serial port:** port for the communication with the supervision system (through a serial interface, via TTL, with MODBUS communication protocol) or with the programming key; by request.

## ITALIANO PREPARATIVI

**1.1 Importante**  
Leggere attentamente queste istruzioni prima dell'installazione e prima dell'uso e seguire tutte le avvertenze per l'installazione e per il collegamento elettrico; conservare queste istruzioni con lo strumento per consultazioni future.

**1.2 Installazione**  
A pannello, con le staffe a scatto in dotazione (si vedano i disegni del paragrafo 1.2 della sezione in Inglese).  
Avvertenze per l'installazione:  
• 59,0 è la profondità massima con morsettiere a vite  
• 83,0 è la profondità massima con morsettiere estraibili  
• lo spessore del pannello non deve essere superiore a 8,0 mm  
• accertarsi che le condizioni di lavoro (temperatura di impiego, umidità, ecc.) rientrino nei limiti indicati nei dati tecnici

- non installare lo strumento in prossimità di fonti di calore (resistenze, condotti dell'aria calda, ecc.), di apparecchi con forti magneti (grossi diffusori, ecc.), di luoghi soggetti alla luce solare diretta, pioggia, umidità, polvere eccessiva, vibrazioni meccaniche o scosse
- in conformità alle normative sulla sicurezza, la protezione contro eventuali contatti con le parti elettriche deve essere assicurata mediante una corretta installazione dello strumento; tutte le parti che assicurano la protezione devono essere fissate in modo tale da non poter essere rimosse senza l'aiuto di un utensile.

**1.3 Collegamento elettrico**  
Si vedano i disegni del paragrafo 1.3 della sezione in Inglese.

Con riferimento agli schemi elettrici:  
• la porta seriale (su richiesta) è la porta per la comunicazione con il sistema di supervisione (attraverso un'interfaccia seriale, via TTL, con protocollo di comunicazione MODBUS) o con la chiave di programmazione; la porta non deve essere utilizzata contemporaneamente per i due scopi.

Avvertenze per il collegamento elettrico:  
• non operare sulle morsettiere utilizzando avvitatori elettrici o pneumatici  
• se lo strumento è stato portato da un luogo freddo a uno caldo, l'umidità potrebbe condensare all'interno; attendere circa un'ora prima di alimentarlo  
• accertarsi che la tensione di alimentazione, la frequenza e la potenza elettrica operativa dello strumento corrispondano a quelle dell'alimentazione locale  
• disconnettere l'alimentazione prima di procedere con qualunque tipo di manutenzione  
• non utilizzare lo strumento come dispositivo di sicurezza  
• per le riparazioni e per informazioni riguardanti lo strumento rivolgersi alla rete di vendita Evco.

## 2 INTERFACCIA UTENTE

**2.1 Accensione/spengimento dello strumento**  
Per accendere lo strumento è necessario alimentarlo; per spegnerlo basta togliere l'alimentazione.  
Se si manifesta un'interruzione dell'alimentazione quando il conteggio è in corso, il funzionamento dello strumento al ripristino dell'alimentazione dipenderà dal parametro t26.

**2.2 Avvio del conteggio**  
• assicurarsi che non sia in corso alcuna procedura  
• provocare l'evento stabilito con il parametro t11:  
- se t11 = 0, premere **start** o attivare l'ingresso start  
- se t11 = 1, premere **stop**  
- se t11 = 2, attivare l'ingresso start.  
**2.3 Interruzione del conteggio**  
• assicurarsi che il parametro t17 sia impostato a 0  
• provocare l'evento stabilito con il parametro t12:  
- se t12 = 0, premere **stop** o attivare l'ingresso stop  
- se t12 = 1, premere **start**  
- se t12 = 2, attivare l'ingresso stop.

In alternativa:  
• premere **stop** per 4 s.  
**2.4 Sospensione/ripresa del conteggio**  
Per sospendere il conteggio:  
• assicurarsi che il parametro t17 sia impostato a 2  
• provocare l'evento stabilito con il parametro t12:  
- se t12 = 0, premere **stop** o attivare l'ingresso stop  
- se t12 = 1, premere **start**  
- se t12 = 2, attivare l'ingresso stop.  
Se il conteggio viene sospeso quando il carico 1 (o il carico 2) è acceso, lo stato del carico durante la sospensione dipenderà dal parametro t24 (o t25):  
• se t24 (o t25) = 0, il carico verrà spento  
• se t24 (o t25) = 1, il carico rimarrà acceso.

Per riprendere il conteggio:  
• provocare l'evento stabilito con il parametro t11:  
- se t11 = 0, premere **start** o attivare l'ingresso start  
- se t11 = 1, premere **stop**  
- se t11 = 2, attivare l'ingresso start.  
**2.5 Il display**  
Se il conteggio è in corso, il display visualizzerà il tipo di conteggio stabilito con il parametro t15:  
• se t15 = 0, il display visualizzerà il tempo residuo (count down)  
• se t15 = 1, il display visualizzerà il tempo trascorso (count up).  
Se il conteggio è sospeso, il display lampeggerà.

**2.6 Tactizione buzzer in allarme**  
• premere un tasto (la prima pressione del tasto non provoca l'effetto associato).

